

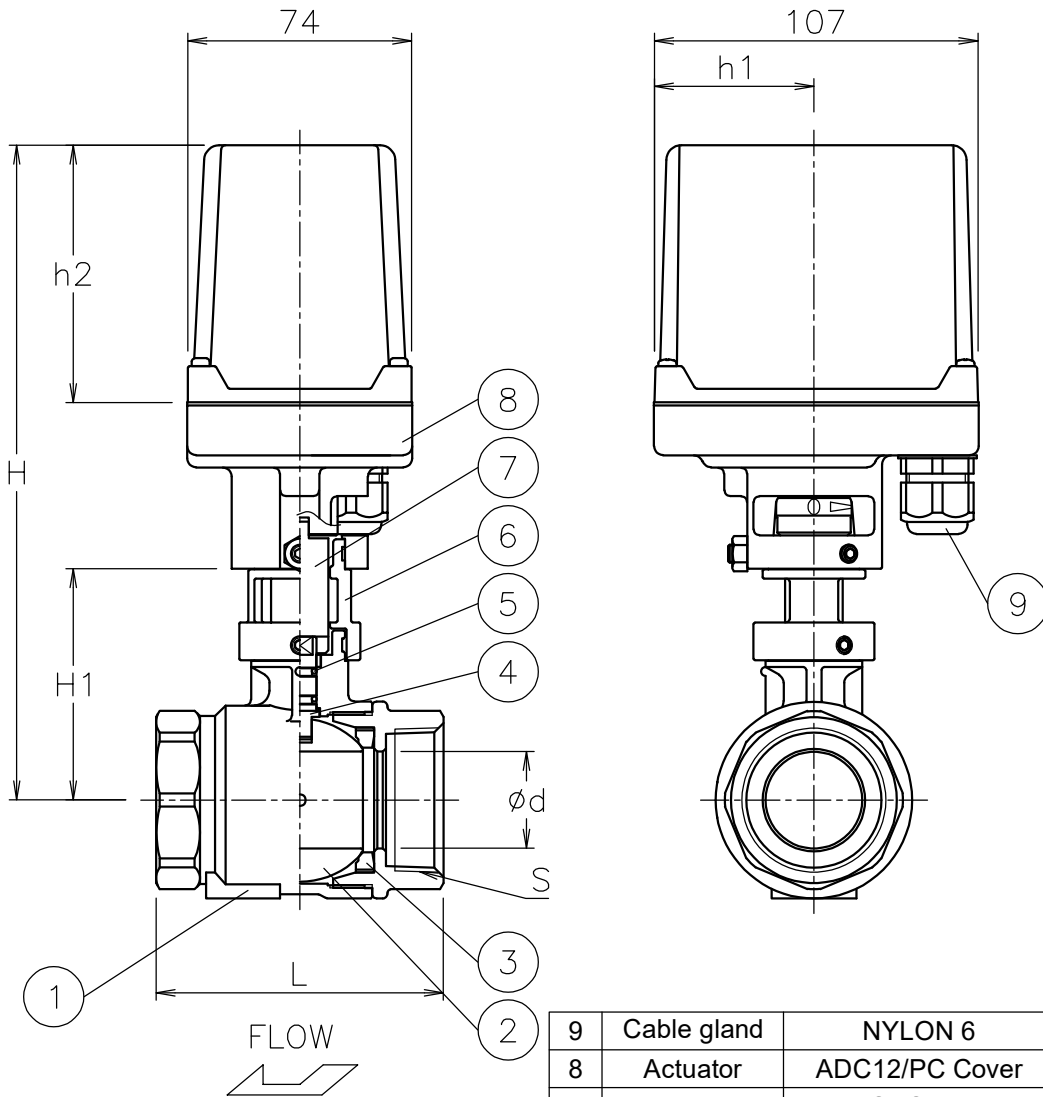

Size [mm]	S	d	L	H1	h1	h2	H	Weight [kg]	Cv	Actuator		Sizing code
										AM1-030	AM2-030	
15	Rc 1/2	13	59	52	36	58	151	1.5	9	AM1-030	AM2-030	0
20	Rc 3/4	15	66	54	36	58	153	1.6	13	AM1-030	AM2-030	0
25	Rc 1	20	78	61	36	58	160	1.8	24	AM1-070	AM2-070	0
					53	85	201	2.3		AM1-180	AM2-180	2
32	Rc1 1/4	25	87	71	36	58	170	2.1	44	AM1-070	AM2-070	0
					53	85	211	2.6		AM1-180	AM2-180	2
40	Rc1 1/2	32	95	77	53	85	217	3	80	AM1-180	AM2-180	0
50	Rc 2	40	109	83	53	85	223	3.6	120	AM1-180	AM2-180	0



NOTE  
(a) Cable acceptance 5φ to 10.5φ mm.

9	Cable gland	NYLON 6	1	G 3/8 (a)
8	Actuator	ADC12/PC Cover	1	
7	Joint	SUS303	1	
6	Bracket	SCS13A	1	
5	O-ring	Steam resistant FKM	2	
4	Stem	SUS316	1	Cr plated
3	Seat	R-PTFE	2	
2	Ball	SCS14A	1	
1	Body	SCS14A	1	
No	DESCRIPTION	MATERIALS	REQ'D	REMARKS

			APPR'D	H.F	TITLE	Threaded End Rc EG type motorized ball valve					
			CHK'D	K.Y							
			DESIGN		MODEL	AM1EG**5UUP AM2EG**5UUP					
			DRAWN	S.O							
MARK	DATE	BY	DATE	'21-03-23	SCALE	NON	DWG No.	EG-*5UUP-AM7-EN			
REVISIONS			 <b>NIPPON VALVE CONTROLS, INC.</b>								
MV-2890											