

Size [mm]	S	d	L	H1	h1	h2	H	Weight [kg]		Cv	Actuator		Sizing code
								AH1	DM*		AH1-030	DM*-030	
15	Rc 1/2	13	59	52	36	85 (58)	178 (151)	1.6	1.8 (1.4)	9	AH1-030	DM*-030	0
20	Rc 3/4	15	66	54	36	85 (58)	180 (153)	1.7	1.9 (1.5)	13	AH1-030	DM*-030	0
25	Rc 1	20	78	61	36	85	187	2.1	2.1	24	AH1-070	DM*-070	0
32	Rc1 1/4	25	87	71	36	85	197	2.4	2.4	44	AH1-070	DM*-070	0
40	Rc1 1/2	32	95	77	53	85	217	3.2	3	80	AH1-180	DM*-180	0
50	Rc 2	40	109	83	53	85	223	3.8	3.6	120	AH1-180	DM*-180	0

( ): DM2-030

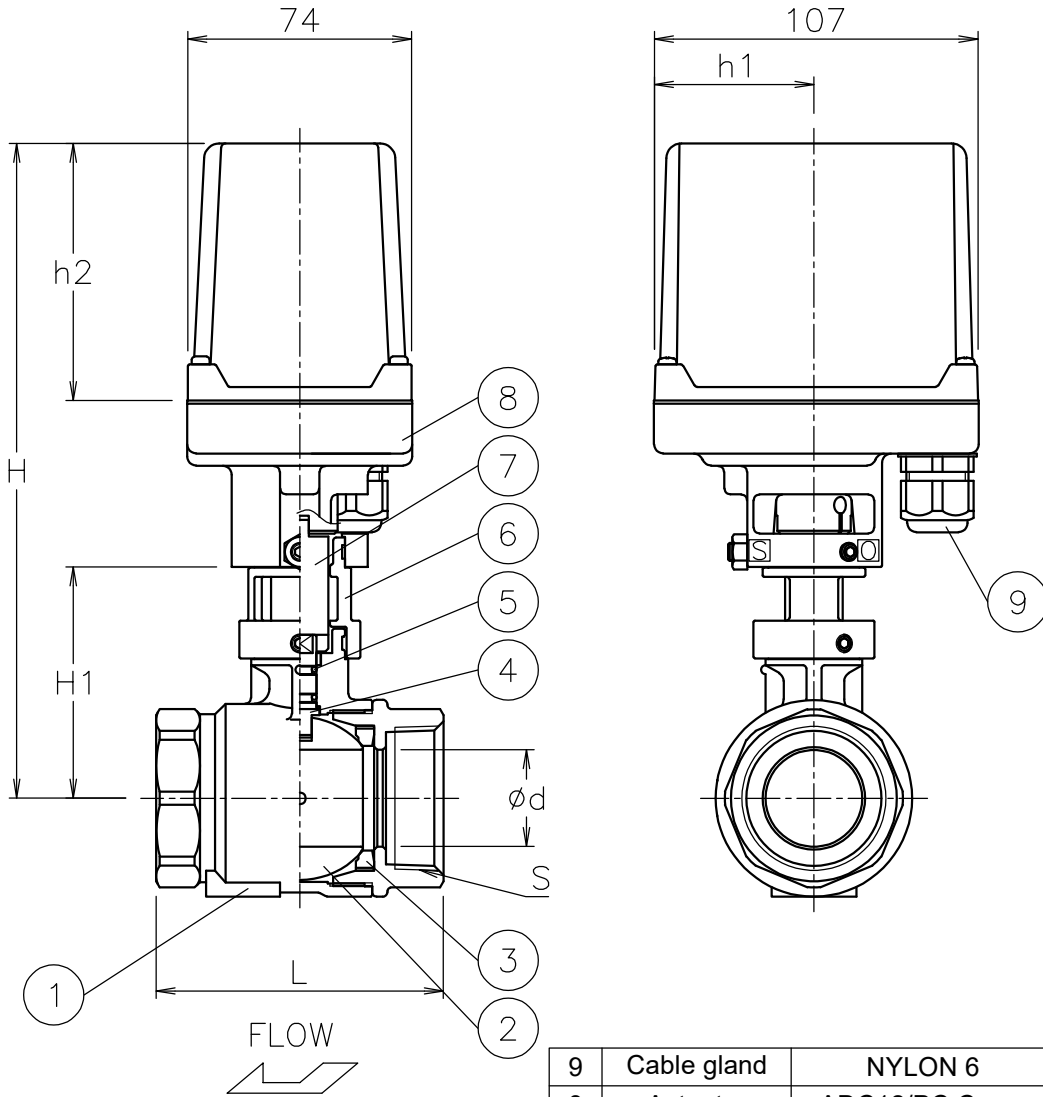

**NOTE**

(a) Cable acceptance 5φ to 10.5φ mm.

9	Cable gland	NYLON 6	1	G 3/8 (a)
8	Actuator	ADC12/PC Cover	1	
7	Joint	SUS303	1	
6	Bracket	SCS13A	1	
5	O-ring	Steam resistant FKM	2	
4	Stem	SUS316	1	Cr plated
3	Seat	R-PTFE	2	
2	Ball	SCS14A	1	
1	Body	SCS14A	1	
No	DESCRIPTION	MATERIALS	REQ'D	REMARKS

				H.F	TITLE	Threaded End Rc EG type motorized ball valve			
			CHK'D	K.Y					
			DESIGN		MODEL	AH1EG*05UUP DM0EG005UUP DM2EG005UUP			
			DRAWN	S.O					
MARK	DATE	BY	DATE	'21-03-23	SCALE	NON	DWG No.	EG-05UUP-CM8-EN	
REVISIONS			 <b>NIPPON VALVE CONTROLS, INC.</b>						
MV-2890									