

Size [mm]	S	d	L	W	N	N1	H	Weight [kg]	Cv	Actuator	Sizing code
8	Rc 1/4	8.5	46	80	57	30	84	0.5	5	PND-03S	0
10	Rc 3/8	9.2	46	80	57	30	84	0.5	5	PND-03S	0
15	Rc 1/2	13	59	80	57	30	86	0.6	12	PND-03S	0
				108	57	30	95	0.7		PND-03D	2
20	Rc 3/4	16	66	80	57	30	89	0.7	16	PND-03S	0
				108	57	30	97	0.8		PND-03D	2
25	Rc 1	20	78	108	57	30	103	1	28	PND-03D	0
32	Rc1 1/4	25	87	108	57	30	114	1.3	47	PND-03D	0
40	Rc1 1/2	32	95	128	68	36	136	1.9	83	PND-04D	0
50	Rc 2	39	109	128	68	36	142	2.4	123	PND-04D	0

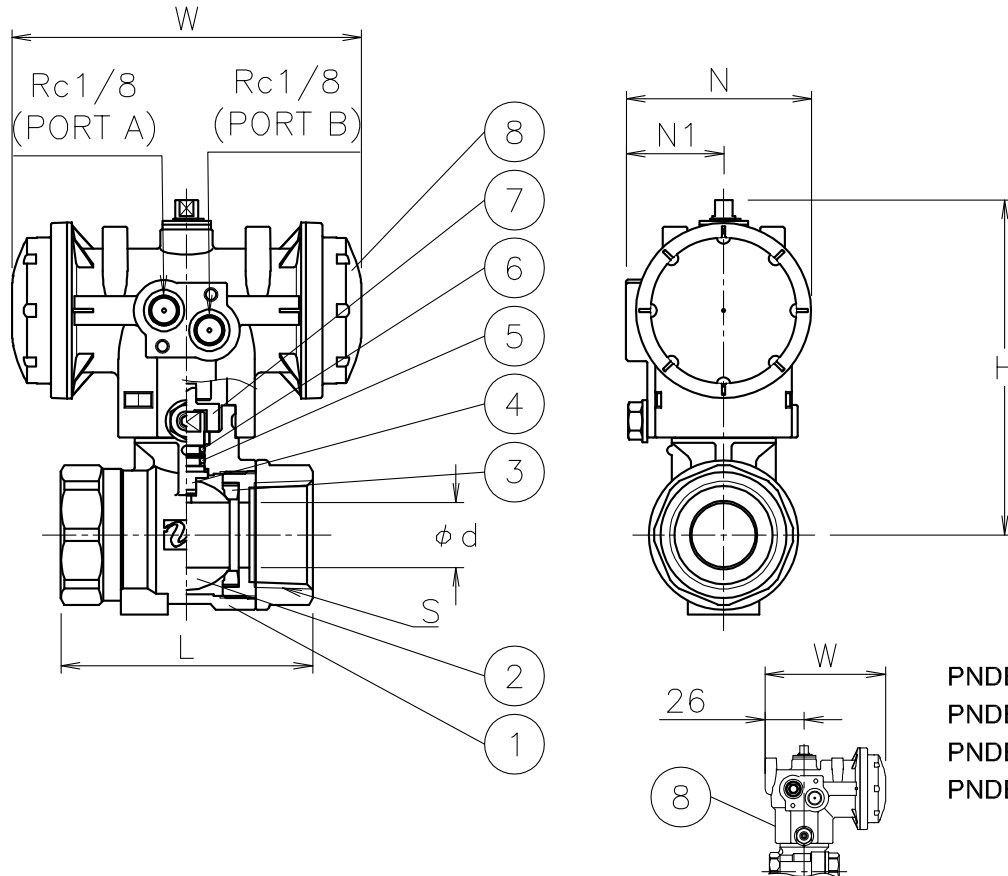

PNDE-905UUT-008
 PNDE-905UUT-010
 PNDE-905UUT-015
 PNDE-905UUT-020

NOTE

- 1) Air supply: 0.4 to 0.5 Mpa. Max 0.7 Mpa.
 - 2) Actuator operation
 Air to port A: SHUT.
 Air to port B: OPEN.
- (a) Coupling OD must be less than 14.5 mm.

8	Actuator	PPS body	1	PND (a)
7	Joint	SUS304	1	
6	O-ring	NBR	1	
5	O-ring	FKM	1	
4	Stem	SUS316	1	Cr plated
3	Seat	PTFE	2	
2	Ball	SUS316/SCS14A	1	
1	Body	SCS14A	1	
No	DESCRIPTION	MATERIALS	REQ'D	REMARKS

			APPR'D	K.Y	TITLE	Threaded End Rc (double-acting type) E type pneumatic actuated ball valve					
			CHK'D	K.Y							
			DESIGN		MODEL	PNDE-9*5UUT					
			DRAWN	T.A							
MARK	DATE	BY	DATE	'22-12-07	SCALE	NON	DWG No.	E-9*5UUT-NA1-EN			
REVISIONS			 NIPPON VALVE CONTROLS, INC.								
MV-2987											