

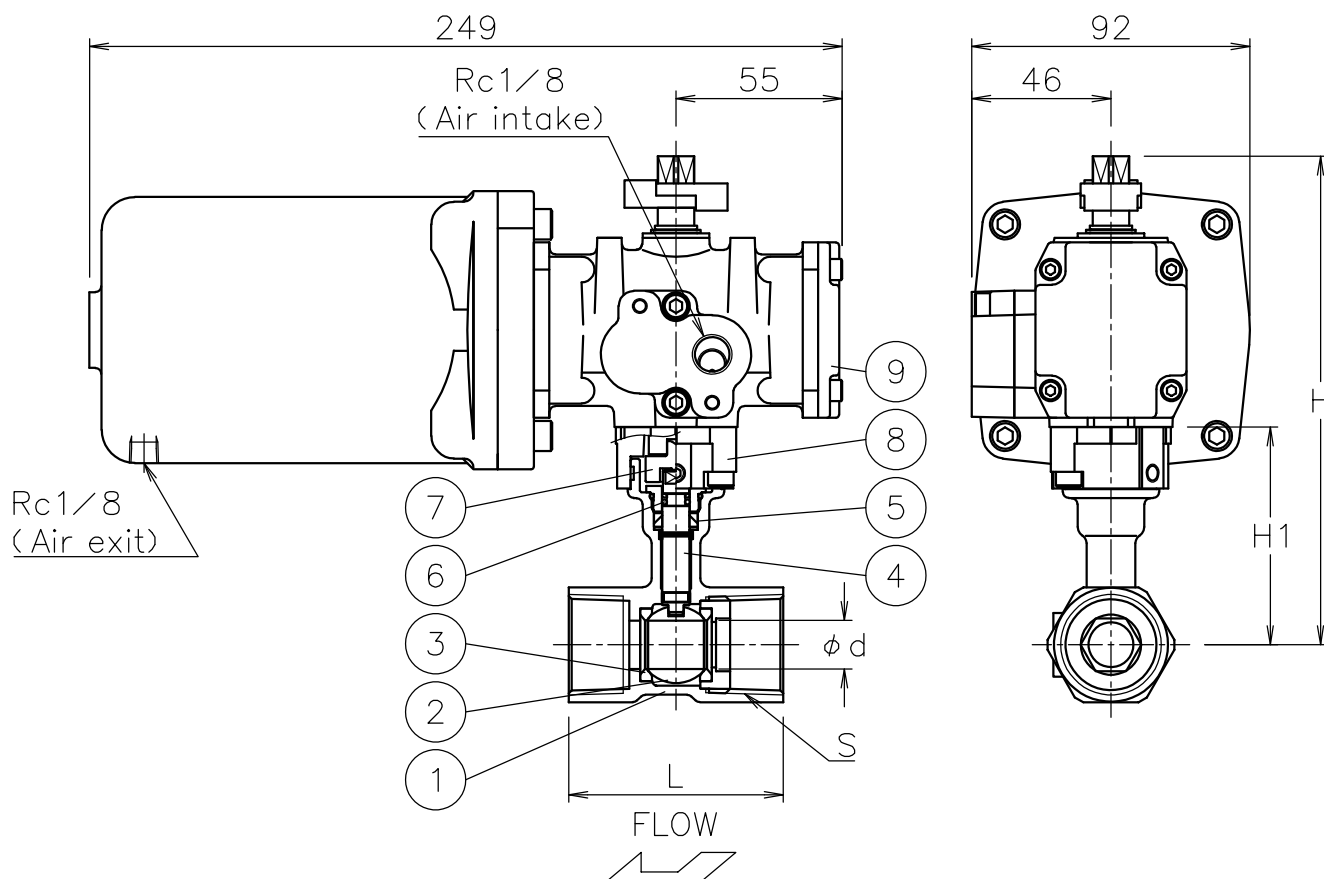

Valve DN	S	d	L	H1	H	Weight (kg)	Cv	Actuator		Sizing code
15 A	Rc 1/2	9	56	67	157	2.7	5	TAO-040	TAC-040	0
20 A	Rc 3/4	12.5	58	70	159	2.8	10	TAO-040	TAC-040	0
25 A	Rc 1	16	71	72	162	3	15	TAO-040	TAC-040	0



NOTE

- Air supply : 0.4~0.5 Mpa max 0.7 Mpa
- Actuator operation
 - TAO serie
 - Air to intake port : OPEN
 - Spring return : SHUT
 - TAC serie
 - Air to intake port : SHUT
 - Spring return : OPEN

9	Actuator		1	TAO/C
8	Bracket	BERIC	1	
7	Joint	SUS304	1	
6	O-ring	FKM	1	
5	Packing	PTFE	1	
4	Stem	SUS304	1	
3	Seat	R-PTFE	2	
2	Ball	SUS304	1	
1	Body	SCS13A	1	
No	DESCRIPTION	MATERIALS	REQ'D	REMARKS

			APPR'D	H.F	Valve DN: 15~25 A					
			CHK'D	K.Y						
			DESIGN							
			DRAWN	P.O	MODEL	TAOAE905TTP		TACAE905TTP		
MARK	DATE	BY	DATE	'16-04-08	SCALE	NON	DWG No.	AE-905TTP-TD2a-EN		
REVISIONS			 NIPPON VALVE CONTROLS, INC.							
MV-2359										