

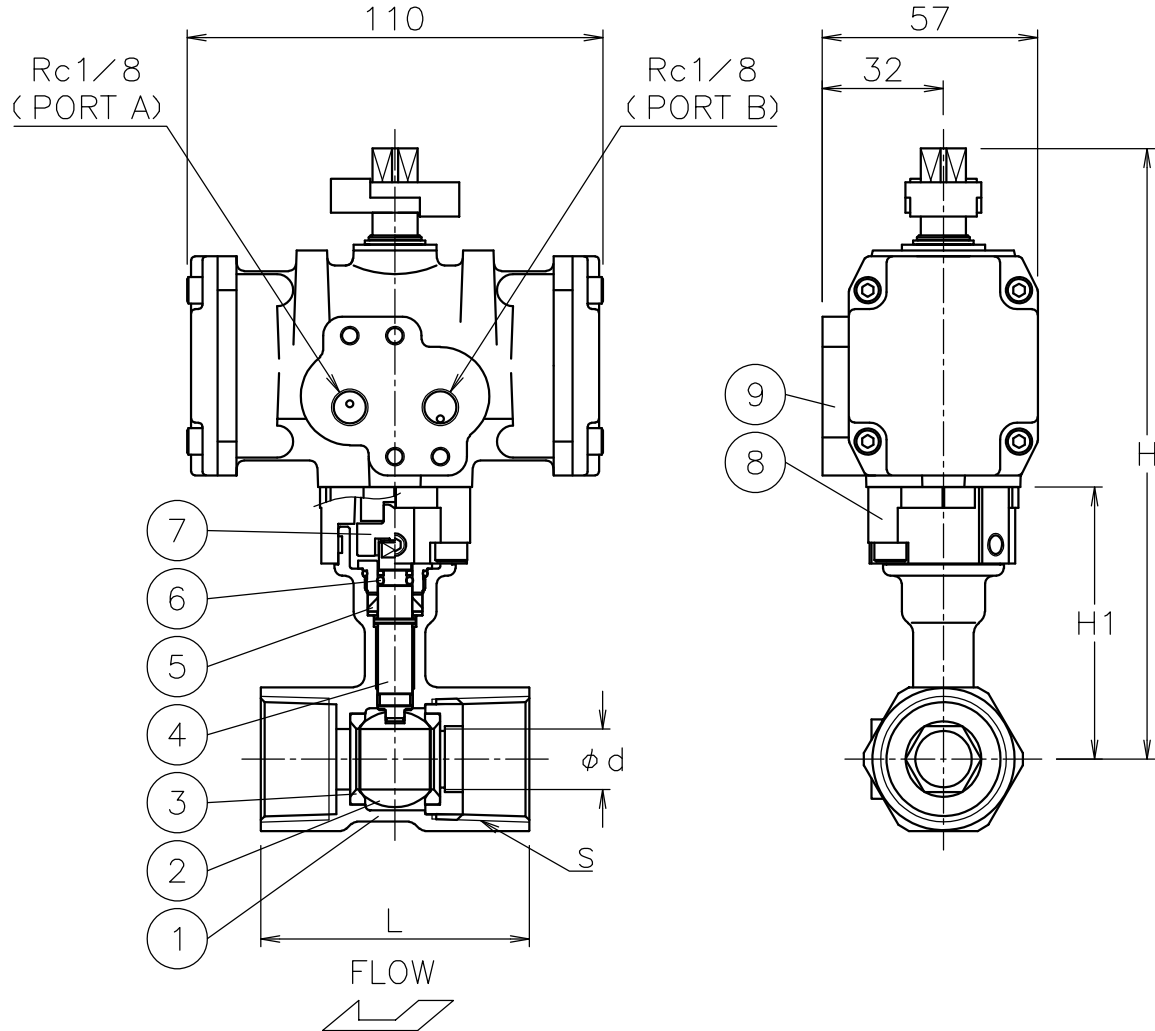

Valve DN	S	d	L	H1	H	Weight (kg)	Cv	Actuator	Sizing code
15 A	Rc 1/2	9	56	67	157	1.3	5	TAD-040	0
20 A	Rc 3/4	12.5	58	70	159	1.3	10	TAD-040	0
25 A	Rc 1	16	71	72	162	1.4	15	TAD-040	0



NOTE

1. Air supply : 0.4~0.5 Mpa max 0.7 Mpa
2. Actuator operation
 - Air to port A : SHUT
 - Air to port B : OPEN

9	Actuator		1	TAD
8	Bracket	BERIC	1	
7	Joint	SUS304	1	
6	O-ring	FKM	1	
5	Packing	PTFE	1	
4	Stem	SUS304	1	
3	Seat	R-PTFE	2	
2	Ball	SUS304	1	
1	Body	SCS13A	1	
No	DESCRIPTION	MATERIALS	REQ'D	REMARKS

			APPR'D	H.F	Valve DN: 15~25 A TITLE Threaded End Rc (double-acting type) AE type pneumatic actuated ball valve				
			CHK'D	K.Y					
			DESIGN						
			DRAWN	P.O	MODEL	TADAE905TTP			
MARK	DATE	BY	DATE	'16-04-08	SCALE	NON	DWG No.	AE-905TTP-TA2a-EN	
REVISIONS			 NIPPON VALVE CONTROLS, INC.						
MV-2359									