

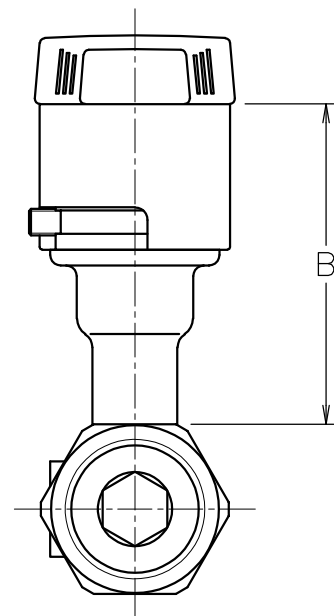

Valve DN	S	d	L	B	H	Weight (kg)	Cv	Actuator
15 A	Rc 1/2	9	56	62	87	0.3	5	Lever
20 A	Rc 3/4	12.5	58	61	90	0.4	10	Lever
25 A	Rc 1	16	71	60	92	0.5	15	Lever

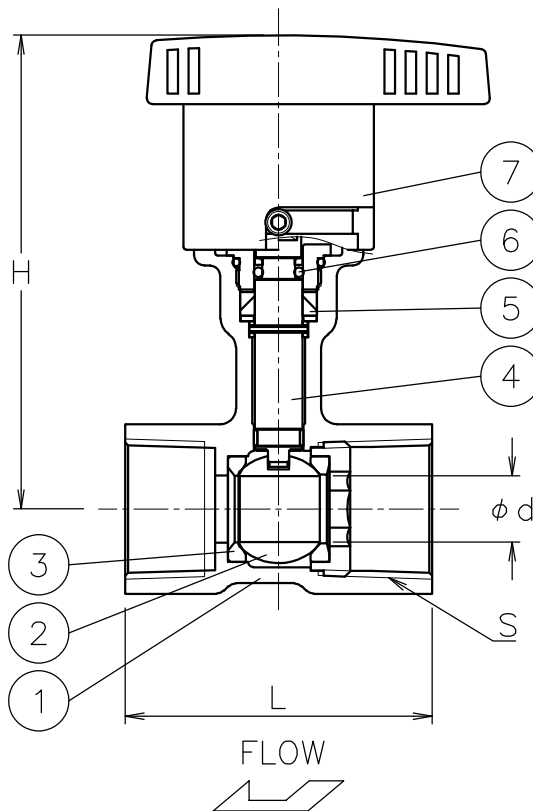
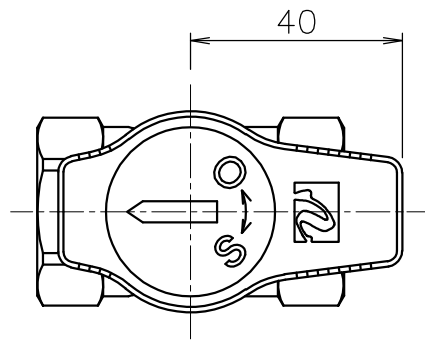

7	Lever handle	SPS	1	
6	O-ring	FKM	1	
5	Packing	PTFE	1	
4	Stem	SUS304	1	
3	Seat	R-PTFE	2	
2	Ball	SUS304	1	
1	Body	SCS13A	1	
No	DESCRIPTION	MATERIALS	REQ'D	REMARKS

			APPR'D	H.F	TITLE	Threaded End Rc Valve DN: 15~25 A AE type ball valve				
			CHK'D	K.Y						
			DESIGN		MODEL	MACAET-5TTP				
			DRAWN	P.O						
MARK	DATE	BY	DATE	'16-04-07	SCALE	NON	DWG No.	AE-5TTP-MA2a-EN		
REVISIONS			 <b>NIPPON VALVE CONTROLS, INC.</b>							
MV-2359										