

Valve DN	S	d	L	H	Weight (kg)	Cv	Actuator	Sizing code
15 A	Rc 1/2	9	56	117	0.6	5	CA1-015	0
20 A	Rc 3/4	12.5	58	120	0.7	10	CA1-015	0

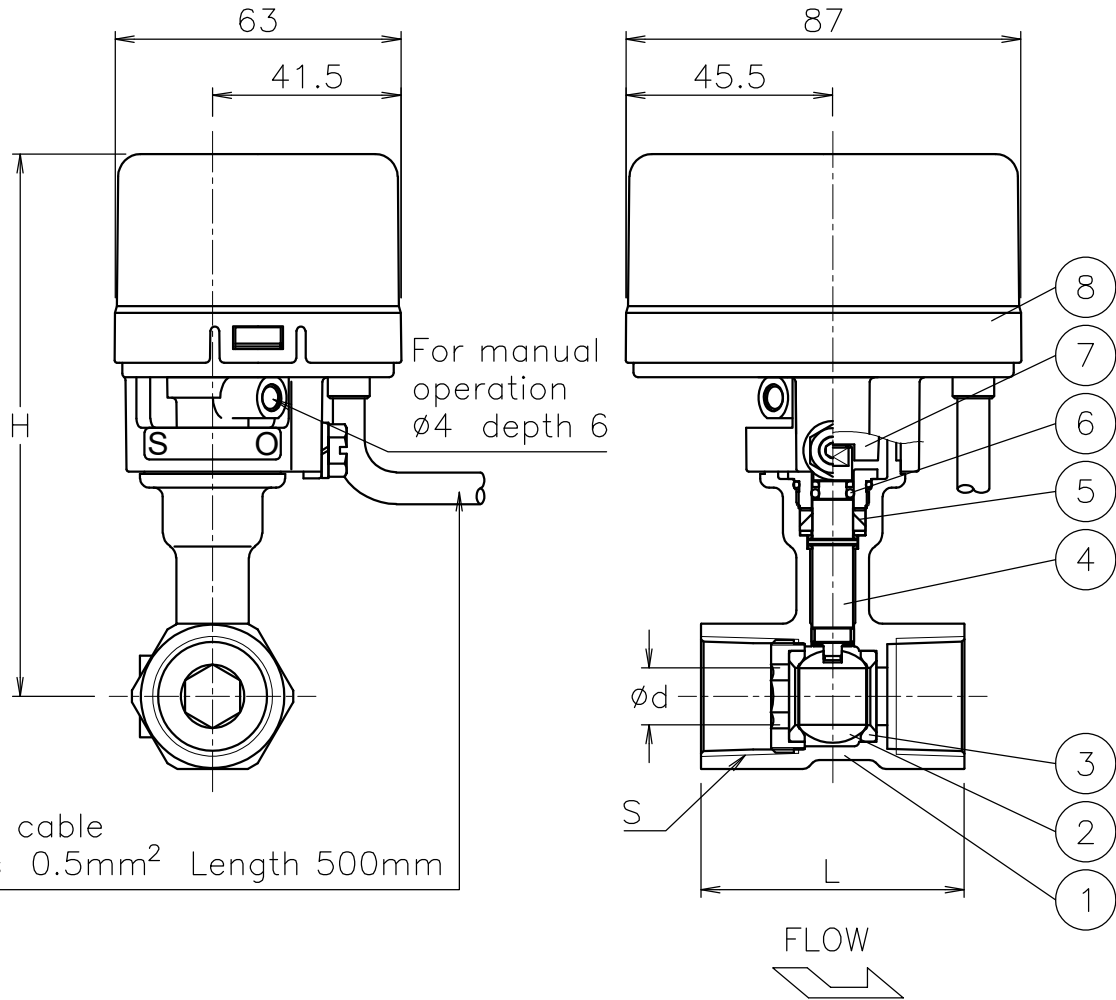

Flexible cable
5 leads 0.5mm² Length 500mm

8	Actuator	PC Case	1	
7	Joint	PPS	1	
6	O-ring	FKM	1	
5	Packing	PTFE	1	
4	Stem	SUS304	1	
3	Seat	R-PTFE	2	
2	Ball	SUS304	1	
1	Body	SCS13A	1	

No	DESCRIPTION	MATERIALS	REQ'D	REMARKS
----	-------------	-----------	-------	---------

			APPR'D	H.F	TITLE	Threaded End Rc Valve DN: 15~20 A					
			CHK'D	K.Y		AE type motorized ball valve					
			DESIGN		MODEL	CA1AE*05TTP					
			DRAWN	P.O							
MARK	DATE	BY	DATE	'16-04-06	SCALE	NON	DWG No.	AE-05TTP-CA3-EN			
REVISIONS											
MV-2395											

NIPPON VALVE CONTROLS, INC.