

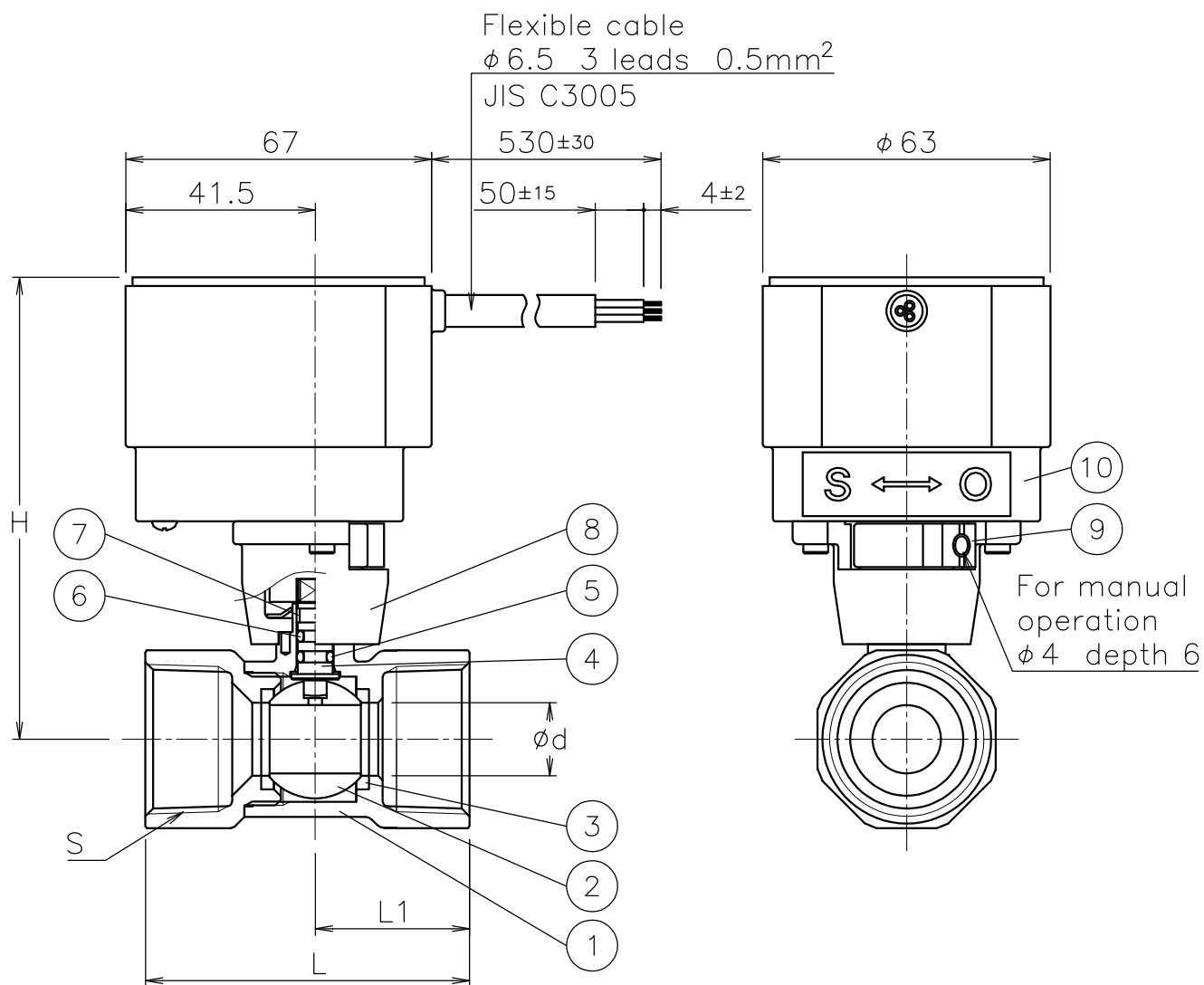

Valve DN	S	d	L	L1	H	Weight (kg)	Cv	Actuator	Sizing code
15 A	Rc 1/2	10	58	27.2	96	0.6	6	PM1-030	0
20 A	Rc 3/4	12.5	63	29.7	98	0.7	11	PM1-030	0
25 A	Rc 1	15	71	33.8	102	0.8	15	PM1-030	0



10	Actuator	PC Case	1	
9	Joint	PPS	1	
8	Bracket	PPS	1	
7	Guide ring	PTFE	1	
6	O-ring	NBR	1	
5	O-ring	FKM	1	
4	Stem	Dezincification resistant brass	1	
3	Seat	F-PTFE	2	
2	Ball	C3604BD	1	PLTD
1	Body	C3771BE	1	PLTD
No	DESCRIPTION	MATERIALS	REQ'D	REMARKS

			APPR'D	H.F	TITLE	Threaded End Rc Valve DN: 15~25 A				
			CHK'D	K.Y		A type motorized ball valve				
			DESIGN		MODEL	PM1A-*05YYF				
			DRAWN	P.O						
MARK	DATE	BY	DATE	'16-04-06	SCALE	NON	DWG No.	A-05YYF-PM1b-EN		
REVISIONS			 NIPPON VALVE CONTROLS, INC.							
MV-2162										