

呼び径	S	d	L	W	B	H	質量(kg)	Cv値	操作機型式
15 A	Rc 1/2	17	59	28	45	71	0.6	7	レバー
20 A	Rc 3/4	23	66	28	48	74	0.7	19	レバー
25 A	Rc 1	28	78	40	52	78	0.9	28	レバー
32 A	Rc1 1/4	31	87	40	52	78	1.1	28	レバー
40 A	Rc1 1/2	43	95	40	65	91	1.7	86	レバー
50 A	Rc 2	48	109	40	65	91	2.2	86	レバー

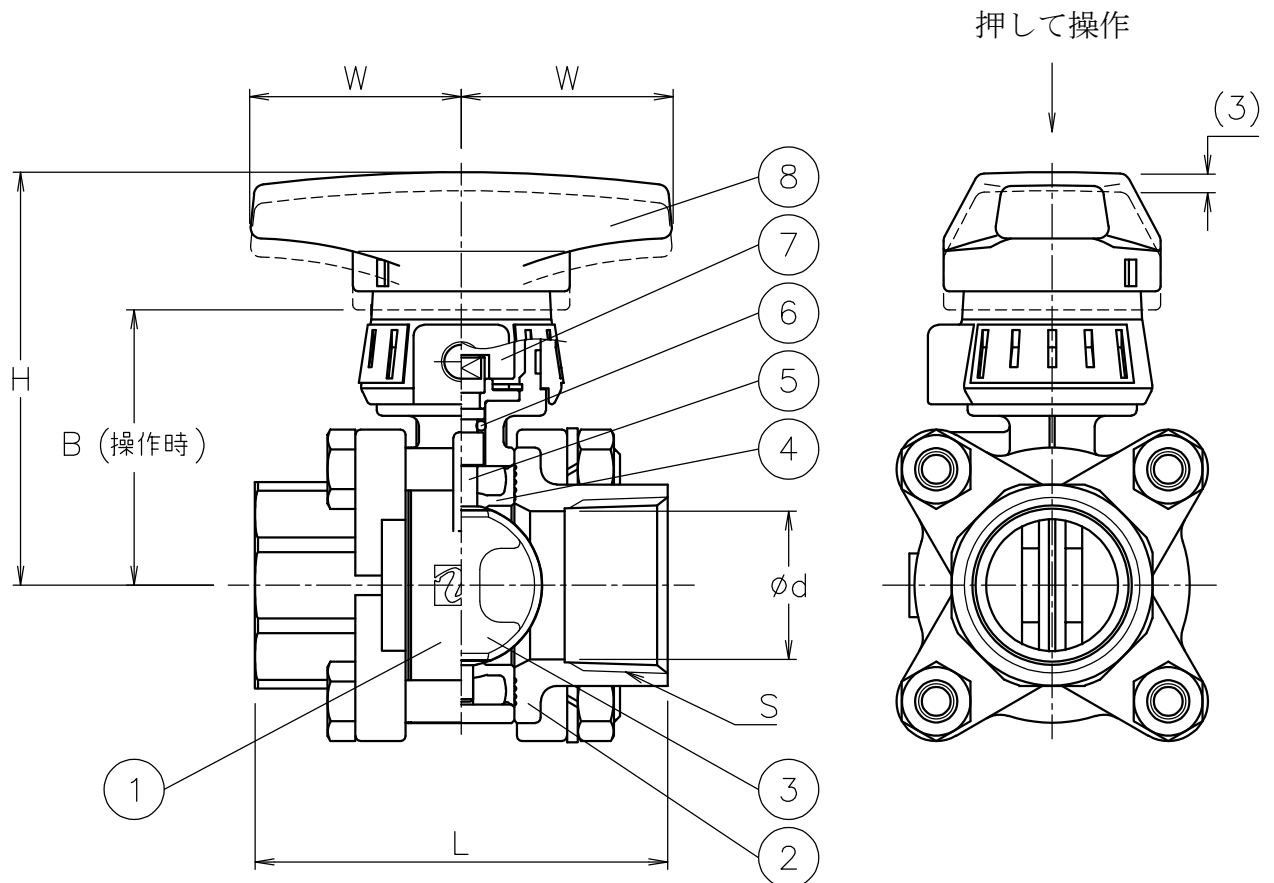

8	手動レバー	ABS樹脂	1	
7	コネクタ	SUS304/PPS樹脂	1	
6	Oリング	NBR	1	
5	ステム	SUS316	1	
4	シート	NBR	1	
3	弁体	PPS樹脂	1	
2	キャップ	SCS14A	2	
1	本体	SCS13A	1	
No	DESCRIPTION	MATERIALS	REQ'D	REMARKS

			APPR'D	H. F	TITLE	Rcねじ込み形 Z型手動バタフライバルブ				
			CHK'D	K. Y						
			DESIGN		MODEL	MACZ-Y-5TUB				
			DRAWN	S. O						
MARK	DATE	BY	DATE	'22-09-26	SCALE	NON	DWG No.	Z-5TUB-MA3		
	REVISIONS				 <b>NIPPON VALVE CONTROLS, INC.</b>					
	MV-2975									