

口径	d	L	D	C	n-h	H	質量(kg)	Cv値	操作機型式			ランク
40 A	40	40	80	95	4-15	331	7.1	85	PHX-300	PHR-300	PDX-300	0
50 A	50	40	90	105	4-15	336	7.2	145	PHX-300	PHR-300	PDX-300	0
65 A	65	40	115	130	4-15	348	7.6	290	PHX-300	PHR-300	PDX-300	0
80 A	80	50	126	145	4-19	380	8.6	450	PHX-300	PHR-300	PDX-300	0
100 A	105	50	146	165	8-19	391	8.9	780	PHX-300	PHR-300	PDX-300	0
125 A	130	50	181	200	8-19	408	9.7	1200	PHX-300	PHR-300	PDX-300	0
150 A	154	50	211	230	8-19	423	12	1800	PHX-300	PHR-300	PDX-300	0
200 A	204	50	257	280	8-23	446	13	3200	PHX-300	PHR-300	PDX-300	0
250 A	253	50	322	345	12-23	468	16	5100	PHX-300	PHR-300	PDX-300	0
							16		PHX-700	PHR-700	PDX-700	2
300 A	300	55	367	390	12-23	494	20	7200	PHX-300	PHR-300	PDX-300	0
							20		PHX-700	PHR-700	PDX-700	2
350 A	340	70	410	435	12-25	545	8900	28	PHX-700	PHR-700	PDX-700	0
						567		29	PHX-02K	PHR-02K	PDX-02K	2
400 A	387	70	470	495	16-25	569	11000	32	PHX-700	PHR-700	PDX-700	0
						591		34	PHX-02K	PHR-02K	PDX-02K	2

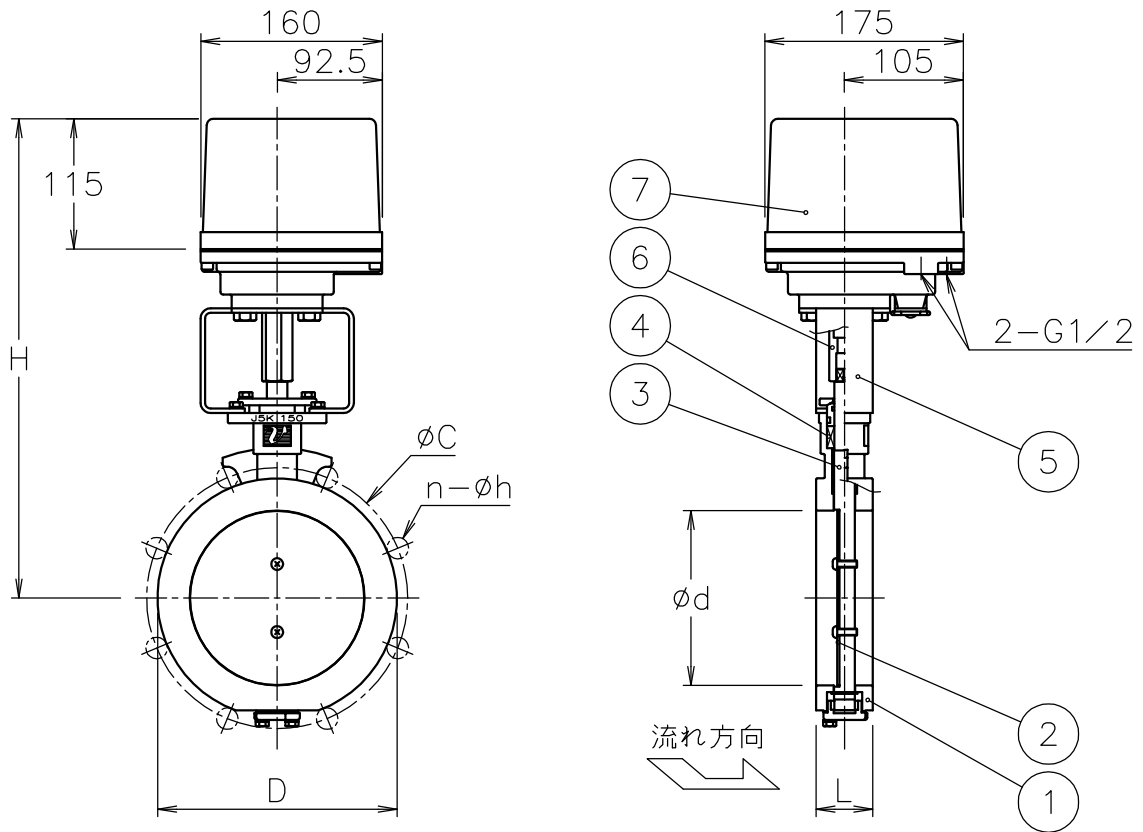

NOTE

(a) 弁体材質 : 300 A 以上は SUS420J1

付属品

- ・ケーブルコネクタ(ナイロン製), G1/2, 適合ケーブルφ6~12
- ・プラグ

7	電動操作機	アルミダ イラストケース	1	
6	コネクタ	SCS13A	1	
5	ブラケット	SUS304	1	
4	グラントパッキン	膨張黒鉛	1	
3	ステム	SUS420J2	1	
2	弁体	SUS420J2	1	(a)
1	本体	SCS13A	1	
No	DESCRIPTION	MATERIALS	REQ'D	REMARKS
TITLE		J 5 K ウエハー式 口径 : 40~400 A WT 型コントロールダンパ		
MODEL		PHXWT**2TG0 PHRWT**2TG0 PDXWT**2TG0		
MARK	DATE	BY	DATE	'08-07-31
REVISIONS		SCALE NON DWG No. WT-*2TG0-PX6		
MV-2142				



NIPPON VALVE CONTROLS, INC.