

呼び径	d	L	L1	D	C	n-h	H	質量(kg)	Cv値	操作機型式		ランク
R15 A	(15)	108	40	95	70	4-15	274	8.1	1.3	PHX-300	PDX-300	0
								8.3		PHX-700	PDX-700	2
15 A	(15)	108	40	95	70	4-15	274	8.1	4	PHX-300	PDX-300	0
								8.3		PHX-700	PDX-700	2
20 A	(20)	117	48	100	75	4-15	277	8.6	7.5	PHX-300	PDX-300	0
								8.8		PHX-700	PDX-700	2
25 A	(25)	127	48.5	125	90	4-19	284	9.9	12	PHX-300	PDX-300	0
								11		PHX-700	PDX-700	2
32 A	(32)	140	60	135	100	4-19	290	12	20	PHX-300	PDX-300	0
								12		PHX-700	PDX-700	2
40 A	(40)	165	67.5	140	105	4-19	299	13	31	PHX-300	PDX-300	0
								13		PHX-700	PDX-700	2
50 A	(50)	178	72	155	120	4-19	308	15	48	PHX-700	PDX-700	0
65 A	(65)	190	85	175	140	4-19	330	20	85	PHX-700	PDX-700	0
80 A	(80)	203	97	185	150	8-19	342	23	123	PHX-700	PDX-700	0
							364	24		PHX-02K	PDX-02K	2

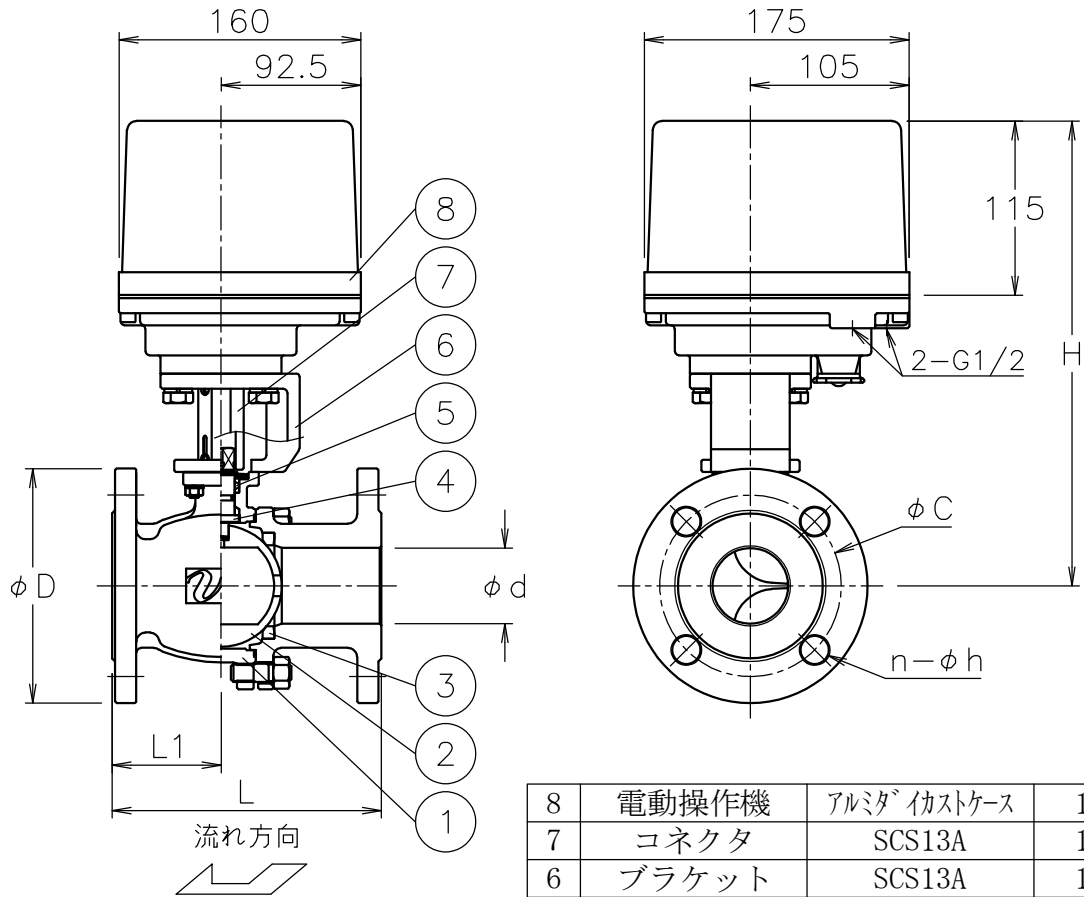

NOTE

付属品

- ・ケーブルラント[®] (ナイロン製), G1/2, 適合ケーブルφ6~12
- ・プラグ

※ 標準仕様ではステムの2次シールとしてFKMのOリングが付いています

8	電動操作機	アルミダ [®] カストケース	1	
7	コネクタ	SCS13A	1	
6	ブラケット	SCS13A	1	
5	パッキン	強化PTFE	1set	
4	ステム	SUS316	1	
3	シート	強化PTFE	2	
2	ボール	SUS316/SCS14A	1	
1	本体	SCS14A	1	
No	DESCRIPTION	MATERIALS	REQ' D	REMARKS

			APPR' D	H. F	TITLE	J10Kフランジ形 VR型コントロールバルブ					
			CHK' D	K. Y							
			DESIGN		MODEL	PHXVR**1UUG PDXVR**1UUG					
			DRAWN	S. O							
MARK	DATE	BY	DATE	'20-10-30	SCALE	NON	DWG No.	VR-*1UUG-PX9			
REVISIONS											
MV-2864											