

呼び径	S	d	L	h1	h2	H	質量(kg)		操作機型式		ランク
							AH1	DM*			
15 A	Rc 1/2	16	75	36	85 (58)	177 (150)	1.7	1.9 (1.5)	AH1-030	DM*-030	0
20 A	Rc 3/4	20	80	36	85	180	2	2	AH1-070	DM*-070	0
25 A	Rc 1	25	88	36	85	191	2.4	2.4	AH1-070	DM*-070	0
				53	85	205	2.8	2.6	AH1-180	DM*-180	2
32 A	Rc1 1/4	32	110	53	85	211	3.3	3.1	AH1-180	DM*-180	0
40 A	Rc1 1/2	38	120	53	85	235	4	3.8	AH1-180	DM*-180	0

( ): DM2-030

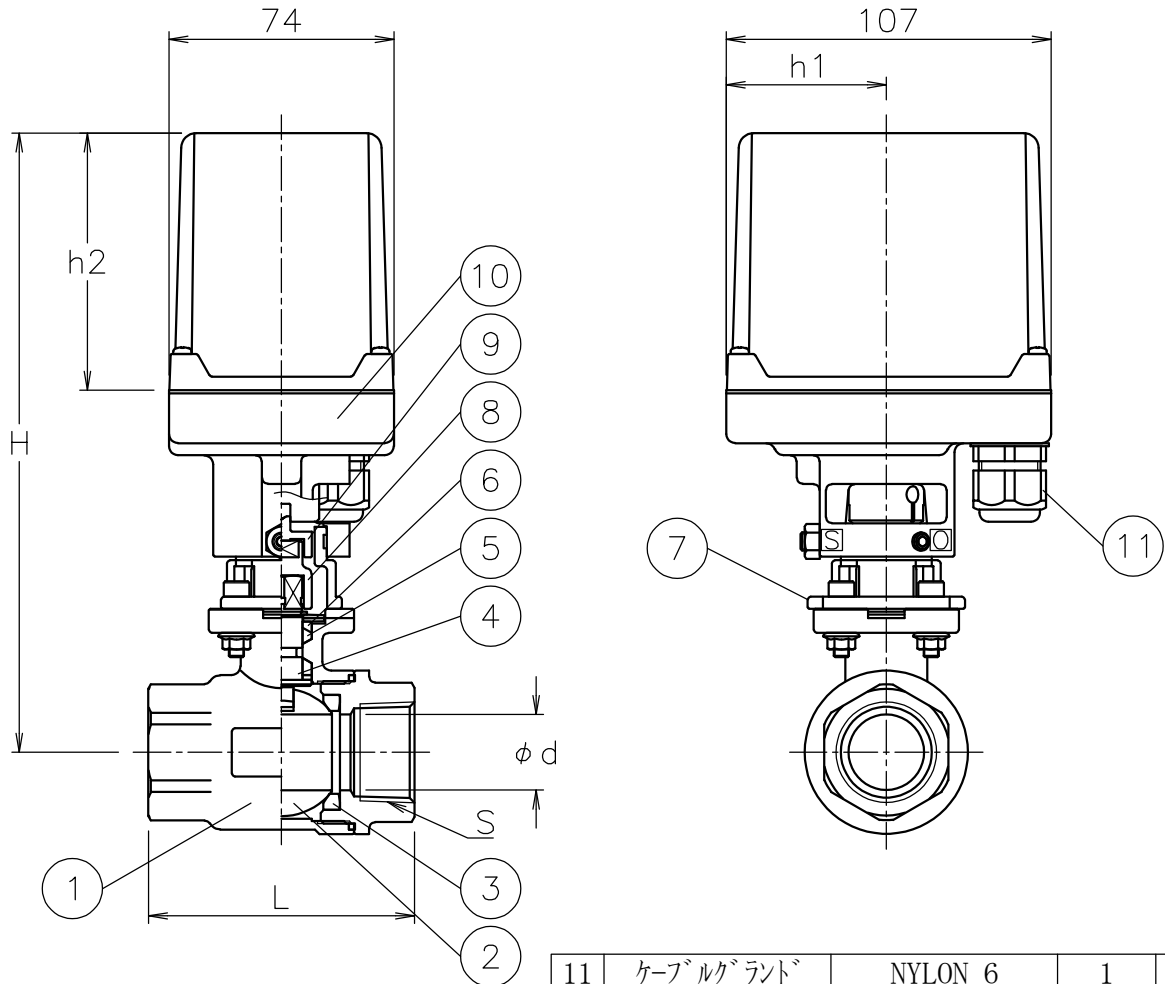

NOTE

(a) ケーブルグランドの適合ケーブル外径はφ5~10.5

11	ケーブルグランド	NYLON 6	1	G3/8 (a)
10	電動操作機	ADC12/PC CASE	1	
9	コネクタ	SUS304	1	
8	コネクタ	SCS13A	1	
7	ブラケット	SCS13A	1	
6	パッキン	強化PTFE	1	
5	パッキン	F-PTFE	1	
4	ステム	SUS316	1	
3	シート	PTFE	2	
2	ボール	SCS14A	1	
1	本体	SCS14A	1	
No	DESCRIPTION	MATERIALS	REQ'D	REMARKS

			APPR'D	H. F	TITLE	Rcねじ込み形				
			CHK'D	K. Y		SR型モータボールバルブ				
			DESIGN		MODEL	AH1SR**5UUT		DMOSR0*5UUT		
			DRAWN	S. O				DM2SR0*5UUT		
MARK	DATE	BY	DATE	'21-06-30	SCALE	NON	DWG No.	SR-*5UUT-CM8		
REVISIONS			 <b>NIPPON VALVE CONTROLS, INC.</b>							
MV-2890										