

呼び径	d	L	t	D	C	n-h	H1	h1	h2	H	質量 [kg]	Cv値 P1/P2	操作機型式		ランク
15 A	15	143	12	95	70	4-15	94	36	58	143	1.6	6.3	AM1-070	AM2-070	0
20 A	20	172	14	100	75	4-15	115	36	58	149	1.9	8.5	AM1-070	AM2-070	0
25 A	25	187	14	125	90	4-19	133	36	58	156	2.4	20	AM1-070	AM2-070	0
32 A	40	212	16	135	100	4-19	165	53	85	234	3.9	27	AM1-180	AM2-180	0
40 A	40	212	16	140	105	4-19	165	53	85	234	3.9	36	AM1-180	AM2-180	0

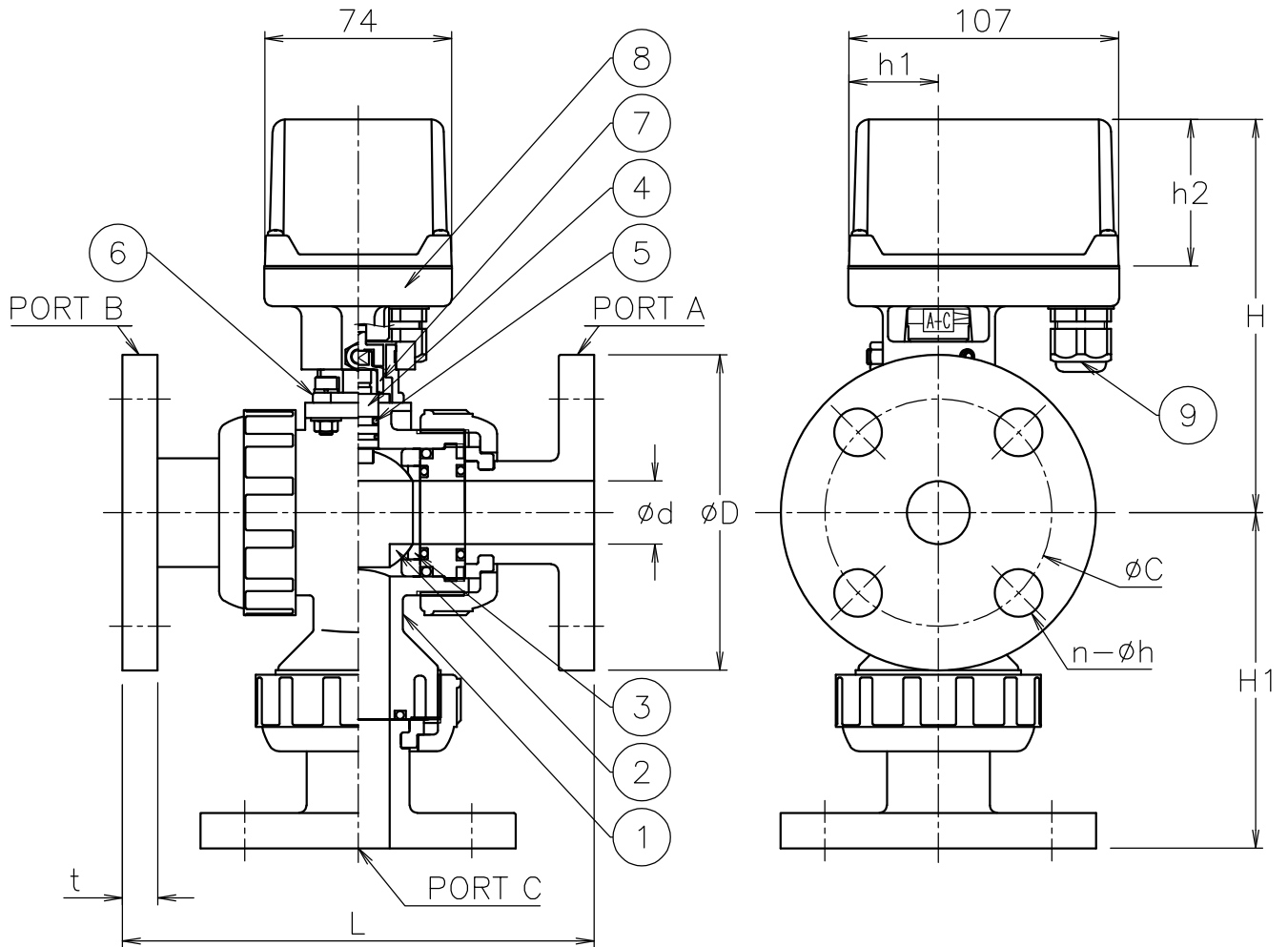

NOTE

(a) 適合ケーブル外径  $\phi 5 \sim 10.5$

切換フォーム

ポジション①(P1)

ポジション②(P2)

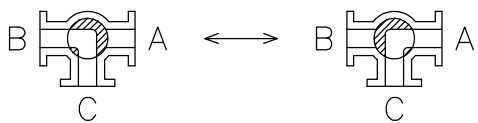

9	ケーブルグランド	NYLON 6	1	G3/8 (a)
8	電動操作機	ADC12/PC CASE	1	
7	コネクタ	SCS13A	1	
6	ブラケット	SCS13A	1	
5	Oリング	EPDM	2	
4	ステム	PVC	1	
3	シート	PTFE	2	
2	ボール	PVC	1	
1	本体	PVC	1	
No	DESCRIPTION	MATERIALS	REQ'D	REMARKS

			APPR'D	H. F	TITLE	J10Kフランジ形 PL型モータボールバルブ								
			CHK'D	K. Y		MODEL	AM1PL*01PPE AM2PL*01PPE							
			DESIGN		MARK		DATE	BY	DATE	'21-12-23	SCALE	NON	DWG No.	PL-01PPE-AM4
			DRAWN	S. O			REVISIONS	MV-2947						
					 <b>NIPPON VALVE CONTROLS, INC.</b>									