

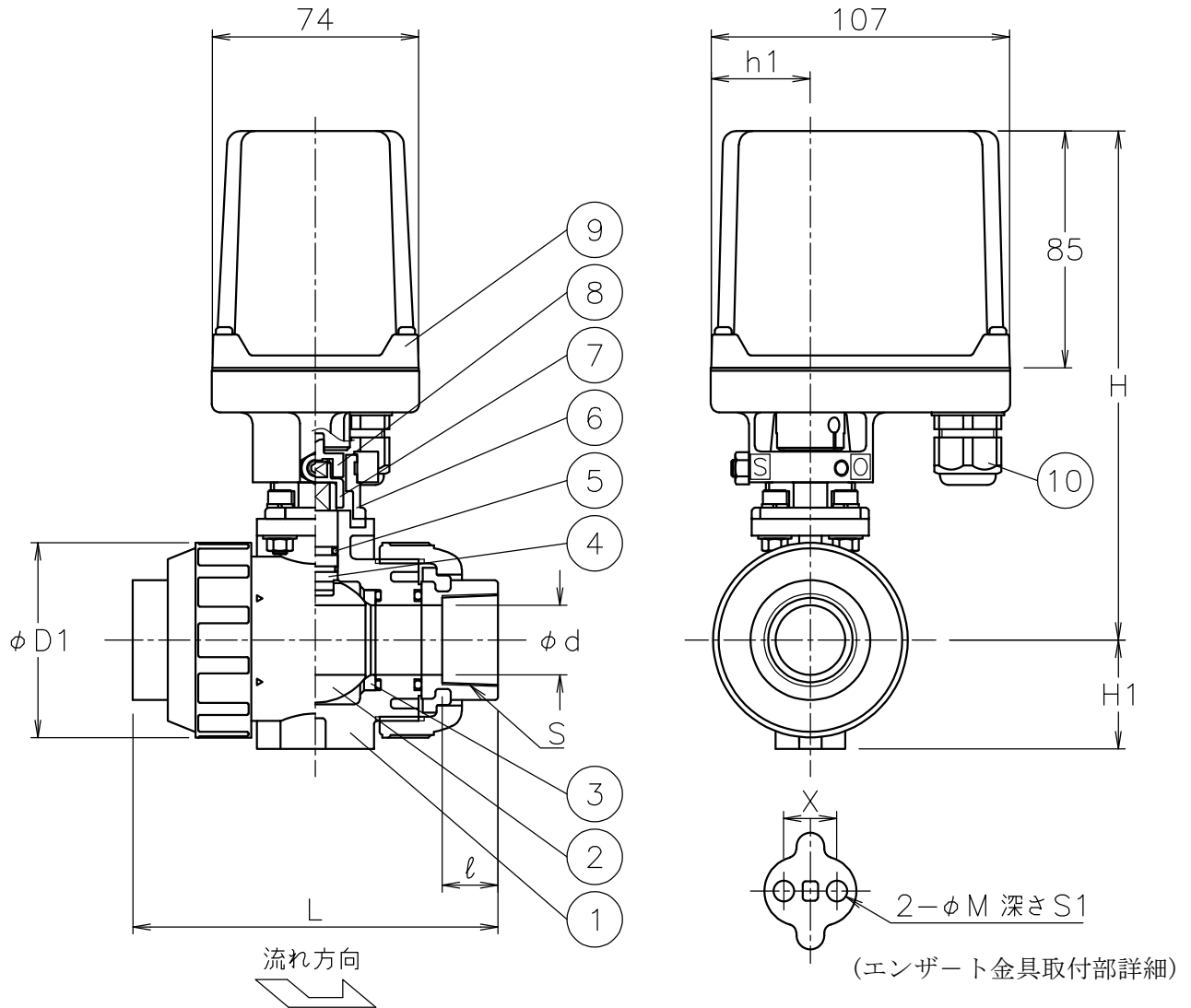

呼び径	S	d	D1	ℓ	L	H1	X	M	S1	h1	H	質量[kg]	Cv値	操作機型式	ランク
15 A	Rc 1/2	15	48	15	100	29	19	7.3	11	36	170	1.4	14	AH1-030	0
20 A	Rc 3/4	20	60	17	119	35	19	7.3	11	36	176	1.7	29	AH1-070	0
25 A	Rc 1	25	70	20	130	39	19	7.3	11	36	183	1.8	47	AH1-070	0
32 A	Rc1 1/4	32	82	22	146	47	30	9	15	36	200	2.1	72	AH1-070	0
40 A	Rc1 1/2	40	100	25	160	55	30	9	15	53	234	2.6	155	AH1-180	0



NOTE

(a) 適合ケーブル外径 φ5~10.5

10	ケーブルランド	NYLON 6	1	G 3/8 (a)
9	電動操作機	ADC12/PC CASE	1	
8	コネクタ	SUS304	1	
7	コネクタ	SCS13A	1	
6	ブラケット	SCS13A	1	
5	Oリング	EPDM	2	
4	ステム	PP	1	
3	シート	PTFE	2	
2	ボール	PP	1	
1	本体	PP	1	
No	DESCRIPTION	MATERIALS	REQ'D	REMARKS

			APPR'D	H. F	TITLE	Rcねじ込み形 PA型モータボールバルブ				
			CHK'D	K. Y		MODEL	AH1PA*05QQE			
			DESIGN		SCALE		NON	DWG No.	PA-05QQE-CM4	
			DRAWN	S. O			DATE	'21-12-23		
MARK	DATE	BY	DATE							
REVISIONS			 NIPPON VALVE CONTROLS, INC.							
MV-2947										