

呼び径	d	L	t	D	C	n-h	H1	X	M	S1	h1	h2	H	質量 [kg]	Cv値	操作機型式		ランク
15 A	15	143	12	95	70	4-15	29	19	7.3	11	36	58	143	1.4	14	AM1-030	AM2-030	0
20 A	20	172	14	100	75	4-15	35	19	7.3	11	36	58	149	1.6	29	AM1-070	AM2-070	0
25 A	25	187	14	125	90	4-19	39	19	7.3	11	36	58	156	1.8	47	AM1-070	AM2-070	0
32 A	32	190	16	135	100	4-19	47	30	9	15	36	58	173	2.1	72	AM1-070	AM2-070	0
40 A	40	212	16	140	105	4-19	55	30	9	15	53	85	234	2.9	155	AM1-180	AM2-180	0

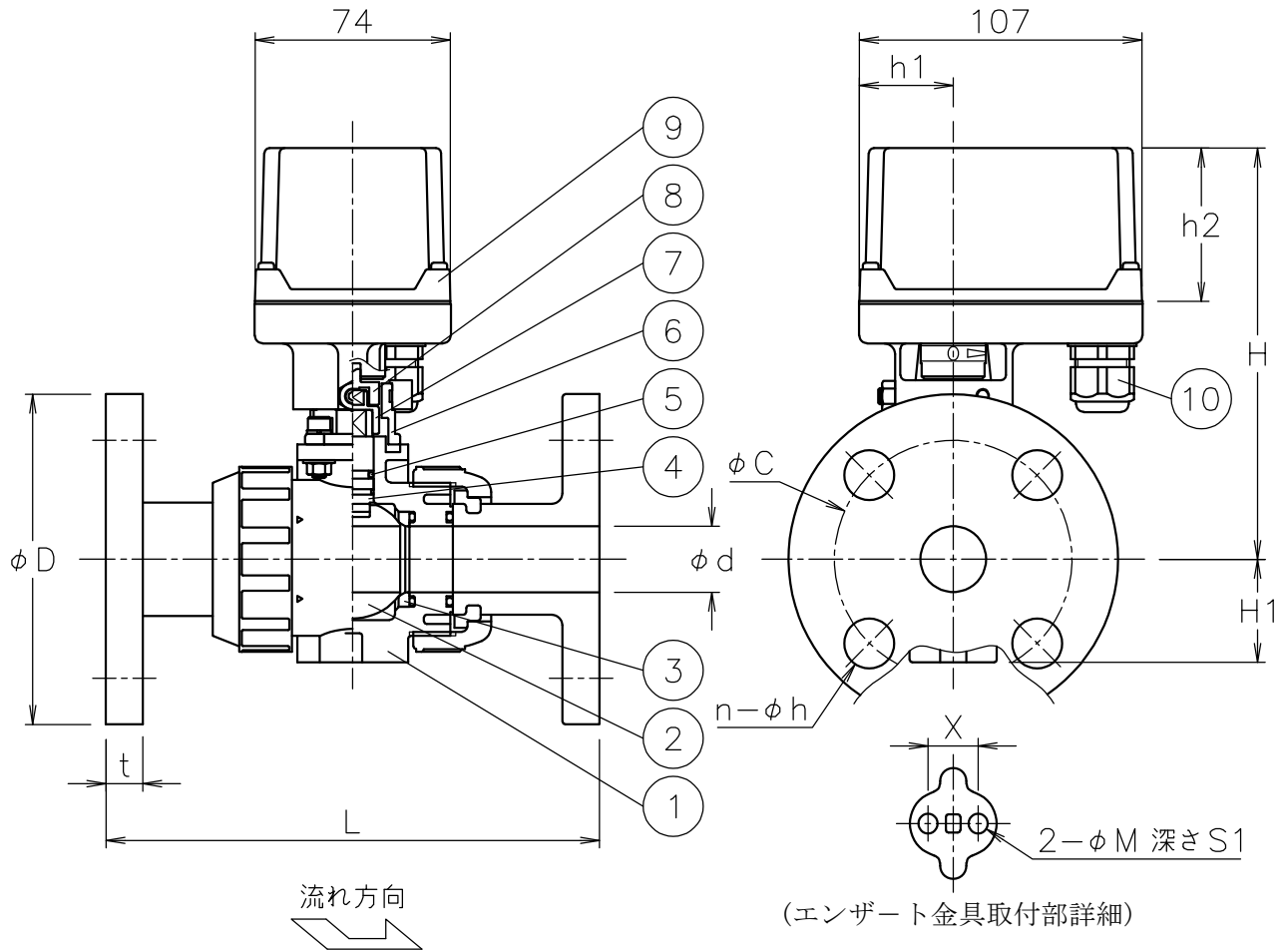

NOTE

(a) 適合ケーブル外径  $\phi 5 \sim 10.5$

10	ケーブルグランド	NYLON 6	1	G3/8 (a)
9	電動操作機	ADC12/PC CASE	1	
8	コネクタ	SUS304	1	
7	コネクタ	SCS13A	1	
6	ブラケット	SCS13A	1	
5	Oリング	FKM	2	
4	ステム	PP	1	
3	シート	PTFE	2	
2	ボール	PP	1	
1	本体	PP	1	
No	DESCRIPTION	MATERIALS	REQ'D	REMARKS

			APPR'D	H. F	TITLE	J10Kフランジ形 PA型モータボールバルブ				
			CHK'D	K. Y						
			DESIGN		MODEL	AM1PA*01QQV AM2PA*01QQV				
			DRAWN	S. O						
MARK	DATE	BY	DATE	'21-12-17	SCALE	NON	DWG No.	PA-01QQV-AM4		
REVISIONS			<b>NIPPON VALVE CONTROLS, INC.</b>							
MV-2945										