

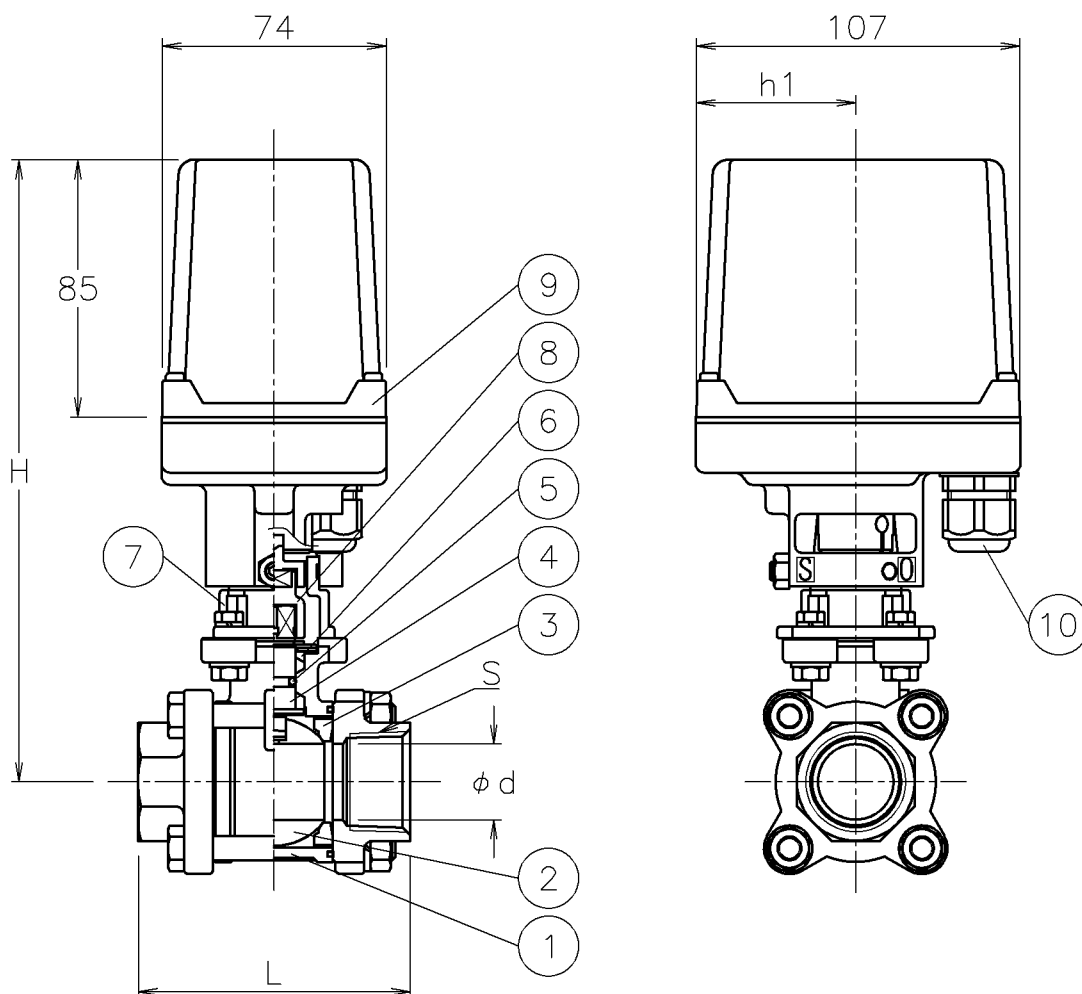

口径	S	d	L	h1	H	質量 (kg)		操作機型式		ランク
						AH1	DM*			
10 A	Rc 3/8	13	60	36	177	1.9	1.9	AH1-070	DM*-070	0
15 A	Rc 1/2	15	75	36	177	2	2	AH1-070	DM*-070	0
				53	192	2.4	2.2	AH1-180	DM*-180	2
20 A	Rc 3/4	20	80	36	180	2.1	2.1	AH1-070	DM*-070	0
				53	195	2.5	2.3	AH1-180	DM*-180	2
25 A	Rc 1	25	90	53	206	2.9	2.7	AH1-180	DM*-180	0



NOTE

(a) ケーブルコネクタの適合ケーブル外径はφ5～10.5

10	電線コネクタ	NYLON 6	1	G 3/8 (a)
9	電動操作機	ADC12/PC CASE	1	
8	コネクタ	SCS13A	1	
7	ブラケット	SCS13A	1	
6	パッキン	強化PTFE	1	
5	Oリング	FKM	1	
4	ステム	SUS316	1	
3	シート	強化PTFE	2	
2	ボール	SCS14A	1	
1	本体	SCS14A	1	
No	DESCRIPTION	MATERIALS	REQ'D	REMARKS

			APPR'D	H. F	TITLE	R c ねじ込み式 口径: 10~25 A				
			CHK'D	K. Y		MS 型モータボールバルブ				
			DESIGN		MODEL	AH1MS**5UUP		DM0MS0*5UUP		
			DRAWN	P. O				DM2MS0*5UUP		
MARK	DATE	BY	DATE	'16-05-31	SCALE	NON	DWG No.	MS-*5UUP-CM15a		
REVISIONS			 NIPPON VALVE CONTROLS, INC.							
MV-2319										