

TA*L3901TTG-025-EP

呼び径	d	L	D	C	n-h	W	W1	W2	N	N1	H	質量 (kg)	Cv値		操作機型式		ランク
													実効	P1/P2			
25 A	25	160	125	90	4-19	305	85	405	103	50	358	13	20	40	TAO-050	TAC-050	0
40 A	40	180	140	105	4-19	367	102	450	119	52	362	18	60	100	TAO-063	TAC-063	0
50 A	50	200	155	120	4-19	367	102	450	119	52	369	21	110	170	TAO-063	TAC-063	0
65 A	65	240	175	140	4-19	435	120	500	142	59	415	31	150	240	TAO-080	TAC-080	0
															TAO-080	TAC-080	0
80 A	76	260	185	150	8-19	435	120	500	142	59	423	35	240	380	TAO-100	TAC-100	2
															TAO-100	TAC-100	0
100 A	100	330	210	175	8-19	530	147	568	174	71	478	54	440	680	TAO-125	TAC-125	2
															TAO-125	TAC-125	0
125 A	122	370	250	210	8-23	688	183	690	193	74	521	81	680	1080	TAO-160	TAC-160	0
150 A	145	430	280	240	8-23	838	223	800	231	82	592	130	1030	1620	TAO-160	TAC-160	0

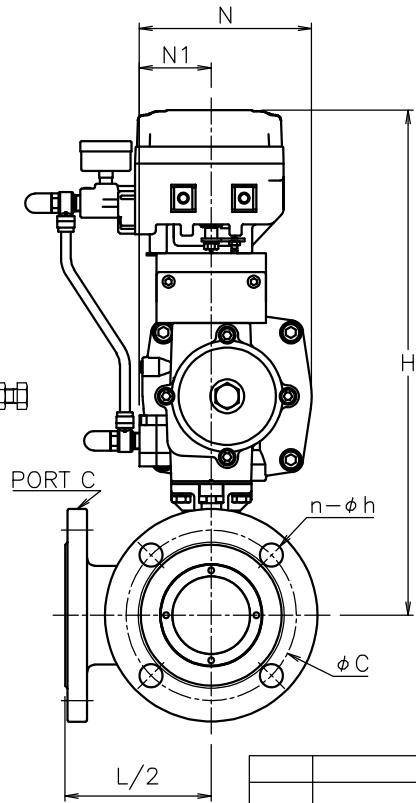
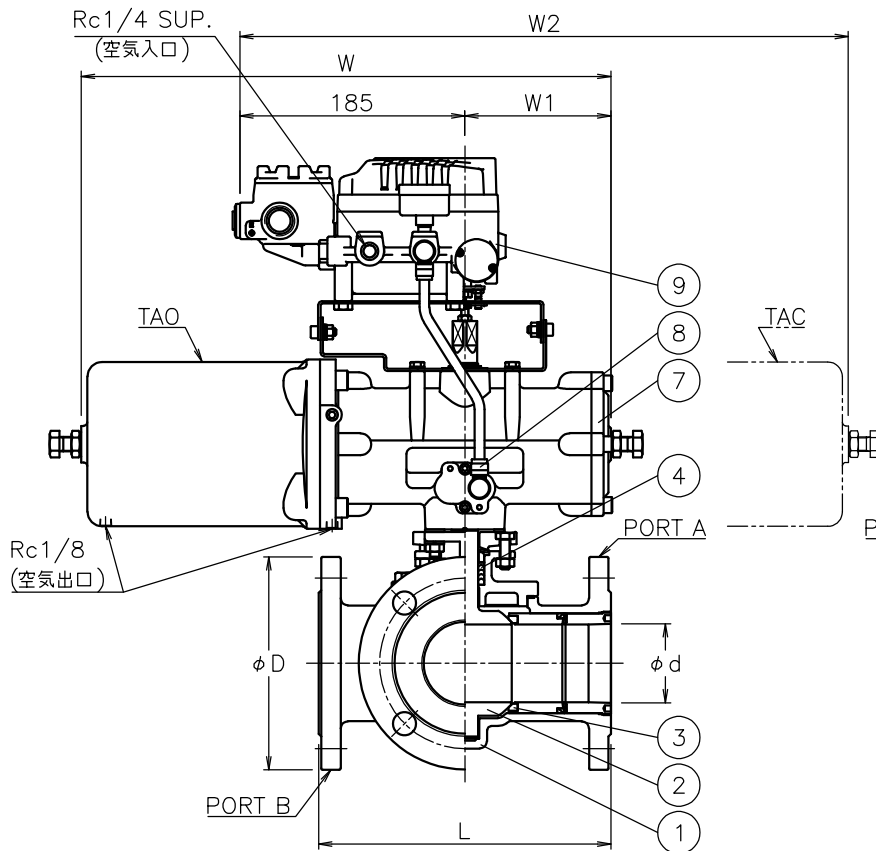

NOTE

- ① 標準操作圧力: 0.4~0.5MPa 最大0.7MPa
- ② 操作機動作

	制御パターン	入力信号		エアレス
		4 mA	20 mA	
TAO	C	P1	P2	P1
	D	P2	P1	P1
TAC	E	P1	P2	P2
	T	P2	P1	P2

※ 図はTAO、制御パターン：Cタイプ

切換フォーム(操作機側から見る)
ポジション①(P1) ポジション②(P2)

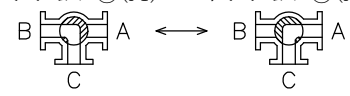

No	DESCRIPTION	MATERIALS	REQ'D	REMARKS
9	電-空ボジショナ		1	EP
8	スピードコントローラ (スパッタタイプ)		2	EP
7	エア作動操作機		1	TAO/C
6	コネクタ	SUS304	1	
5	ブラケット	SCS13A	1	
4	パッキン	PTFE	1	
3	シート	強化PTFE	2	
2	ボール・システム	SCS13A	1	
1	本体	SCS13A	1	

MARK	DATE	BY	DATE	SCALE	NON	DWG No.	L3-9*1TTG-EP-TD5
			21-01-15				
REVISIONS MV-2878				APPR'D CHK'D DESIGN DRAWN	H. F K. Y S. O	TITLE MODEL	J10Kフランジ形 (単作動形) L3型エア作動ボールバルブ TAOL39*1TTG-EP TACL39*1TTG-EP
				NIPPO VALVE CONTROLS, INC.			