

TA*GS923UUM-040
 TA*GS923UUM-050
 TA*GS923UUM-065
 TA*GS923UUM-080

呼び径	d	L	L1	J10K		J20K		W	W1	N	N1	H	質量[kg]	Cv値	操作機型式	リンク
				C	n-h	C	n-h									
15 A	15	40	20	70	4-15	70	4-15	305	85	103	50	224	4.1	20	TA*-050	2
20 A	20	50	25	75	4-15	75	4-15	305	85	103	50	226	4.3	36	TA*-050	2
25 A	25	60	30	90	4-19	90	4-19	367	102	119	52	250	6.7	50	TA*-063	2
32 A	32	70	35	100	4-19	100	4-19	367	102	119	52	254	7.2	90	TA*-063	2
40 A	40	80	40	105	4-19	105	4-19	435	120	142	59	342	13	120	TA*-080	2
50 A	50	95	45	120	4-19	120	8-19	435	120	142	59	350	14	220	TA*-080	2
65 A	64	110	52	140	4-19	140	8-19	530	147	174	71	405	26	380	TA*-100	2
80 A	74	125	61	150	8-19	160	8-23	530	147	174	71	412	28	750	TA*-100	2

NOTE

- ① 標準操作圧力: 0.4~0.5MPa 最大0.7MPa
- ② 操作機動作

	空気導入	空気排出 (スプリング)
TAO	バルブ開	バルブ閉
TAC	バルブ閉	バルブ開

※ 図はTAOを表す

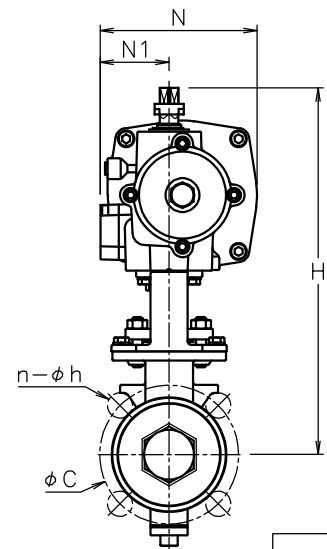
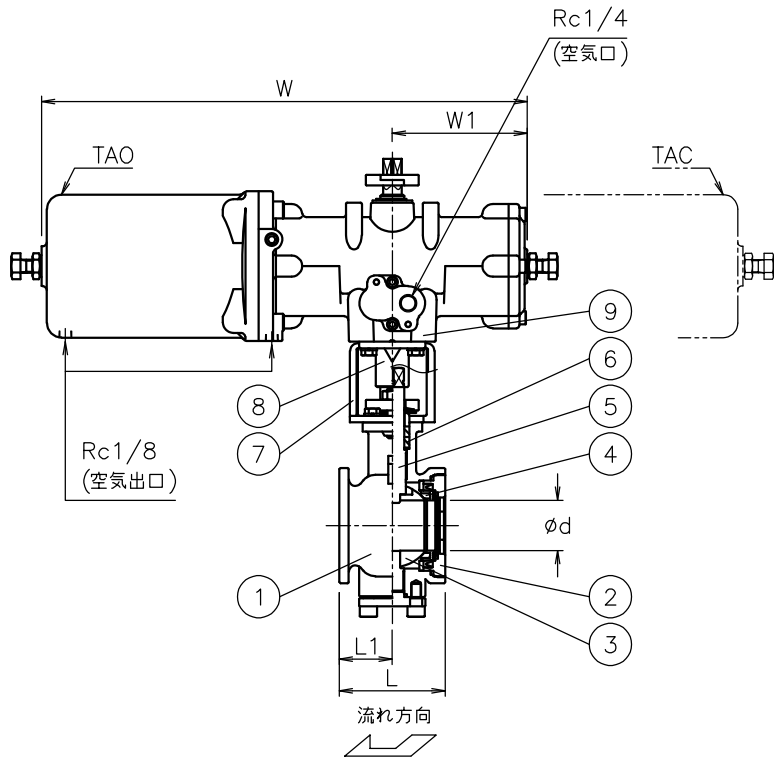

No	DESCRIPTION	MATERIALS	REQ'D	REMARKS
9	エア作動操作機		1	TAO/C
8	コネクタ	SUS304/SCS13A	1	
7	ブラケット	SUS304/SCS13A	1	
6	パッキン	強化PTFE	2	
5	ステム	SUS316	1	
4	シート	SUS316	1	(ステラト盛)
3	ボール	SCS14A	1	HCr PLTD
2	キャップ	SCS14A	1	
1	本体	SCS14A	1	

MARK	DATE	BY	DATE	SCALE	NON	DWG No.	REVISIONS
			22-05-25				
<div style="display: flex; justify-content: space-between; align-items: center;"> <div> <p>REVISIONS</p> <p>MV-2963</p> </div> <div style="text-align: center;"> <p>NIPON VALVE CONTROLS, INC.</p> </div> </div>							

TITLE J10K/20Kウェハー形 (単作動形)
 GS型エア作動ボールバルブ
 MODEL TAOGS923UUM
 TACGS923UUM