

呼び径	d	L	L1	J10K		J20K		H	質量 (kg)	Cv値	操作機型式			ランク
				C	n-h	C	n-h							
15 A	15	40	20	70	4-15	70	4-15	300	6.8	20	PHX-300	PHR-300	PDX-300	0
20 A	20	50	25	75	4-15	75	4-15	302	7	36	PHX-300	PHR-300	PDX-300	0
25 A	25	60	30	90	4-19	90	4-19	311	7.5	50	PHX-300	PHR-300	PDX-300	0
32 A	32	70	35	100	4-19	100	4-19	315	8	90	PHX-300	PHR-300	PDX-300	0
40 A	40	80	40	105	4-19	105	4-19	338	9.3	120	PHX-700	PHR-700	PDX-700	2
50 A	50	95	45	120	4-19	120	8-19	346	11	220	PHX-700	PHR-700	PDX-700	0
65 A	64	110	52	140	4-19	140	8-19	392	16	380	PHX-02K	PHR-02K	PDX-02K	2
80 A	74	125	61	150	8-19	160	8-23	399	18	750	PHX-02K	PHR-02K	PDX-02K	2

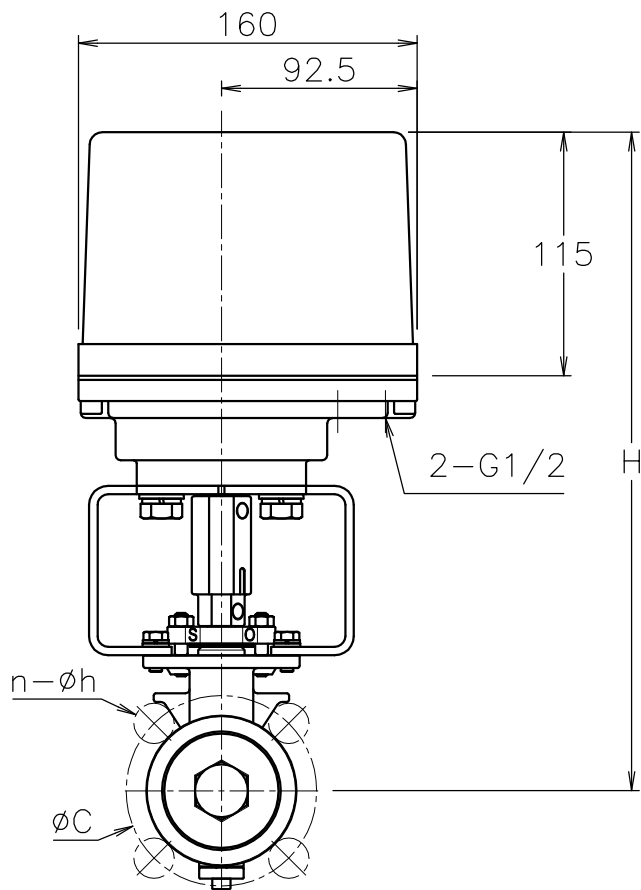
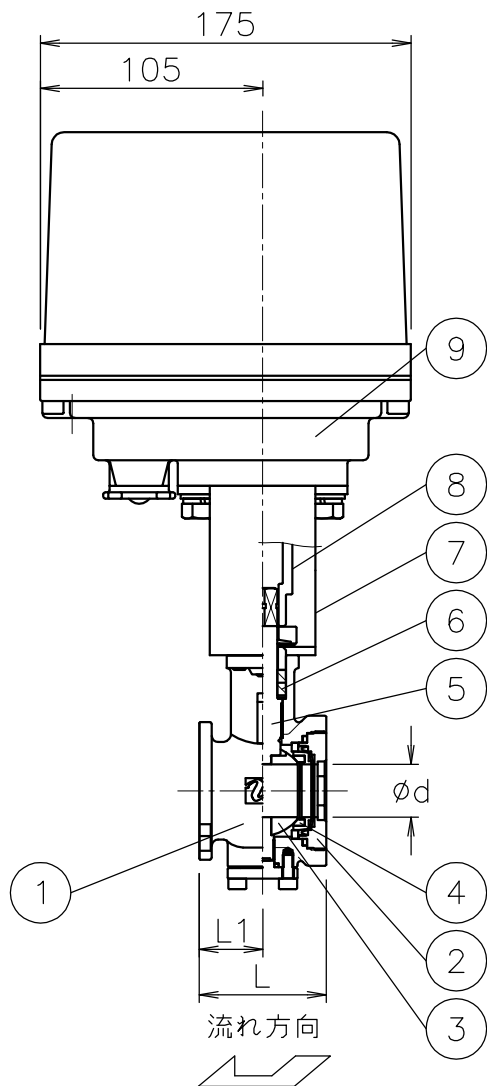

NOTE
付属品

- ・ケーブルコネクタ(ナイロン製), G1/2, 適合ケーブルφ6~12
- ・プラグ

9	電動操作機	アルミダイカストケース	1	
8	コネクタ	SCS13A	1	
7	ブラケット	SUS304	1	
6	パッキン	強化PTFE	2	
5	ステム	SUS316	1	
4	シート	SUS316	1	(ステライト盛)
3	ボール	SCS14A	1	HCr PLTD
2	キャップ	SCS14A	1	
1	本体	SCS14A	1	
No	DESCRIPTION	MATERIALS	REQ'D	REMARKS

			APPR'D	H. F	TITLE	J10K/20K ウエハー式 GS型コントロールバルブ			
			CHK'D	K. Y		MODEL	PHXGS**3UUM	PHRGS**3UUM	PDXGS**3UUM
			DESIGN		SCALE		NON	DWG No.	GS-*3UUM-PX10
MARK	DATE	BY	DATE	'17-03-07					
	REVISIONS								
	MV-2592								



NIPPON VALVE CONTROLS, INC.