

呼び径	d	L	L1	J10K		J20K		W1	W2	W3	W4	W5	H	質量 (kg)	Cv値	操作機型式	ランク
				C	n-h	C	n-h										
15 A	15	40	20	70	4-15	70	4-15	122	60	145	60	102	230	3.6	20	AEX-360	2
20 A	20	50	25	75	4-15	75	4-15	122	60	145	60	102	232	3.8	36	AEX-360	2
25 A	25	60	30	90	4-19	90	4-19	122	60	145	60	102	241	4.3	50	AEX-360	2
32 A	32	70	35	100	4-19	100	4-19	122	60	145	60	102	245	4.7	90	AEX-360	2
40 A	40	80	40	105	4-19	105	4-19	122	60	145	60	102	284	6	120	AEX-700	2
50 A	50	95	45	120	4-19	120	8-19	122	60	145	60	102	292	7.4	220	AEX-700	2
65 A	64	110	52	140	4-19	140	8-19	160	97	175	63	115	397	17	380	AEX-02K	2
80 A	74	125	61	150	8-19	160	8-23	160	97	175	63	115	404	19	750	AEX-02K	2

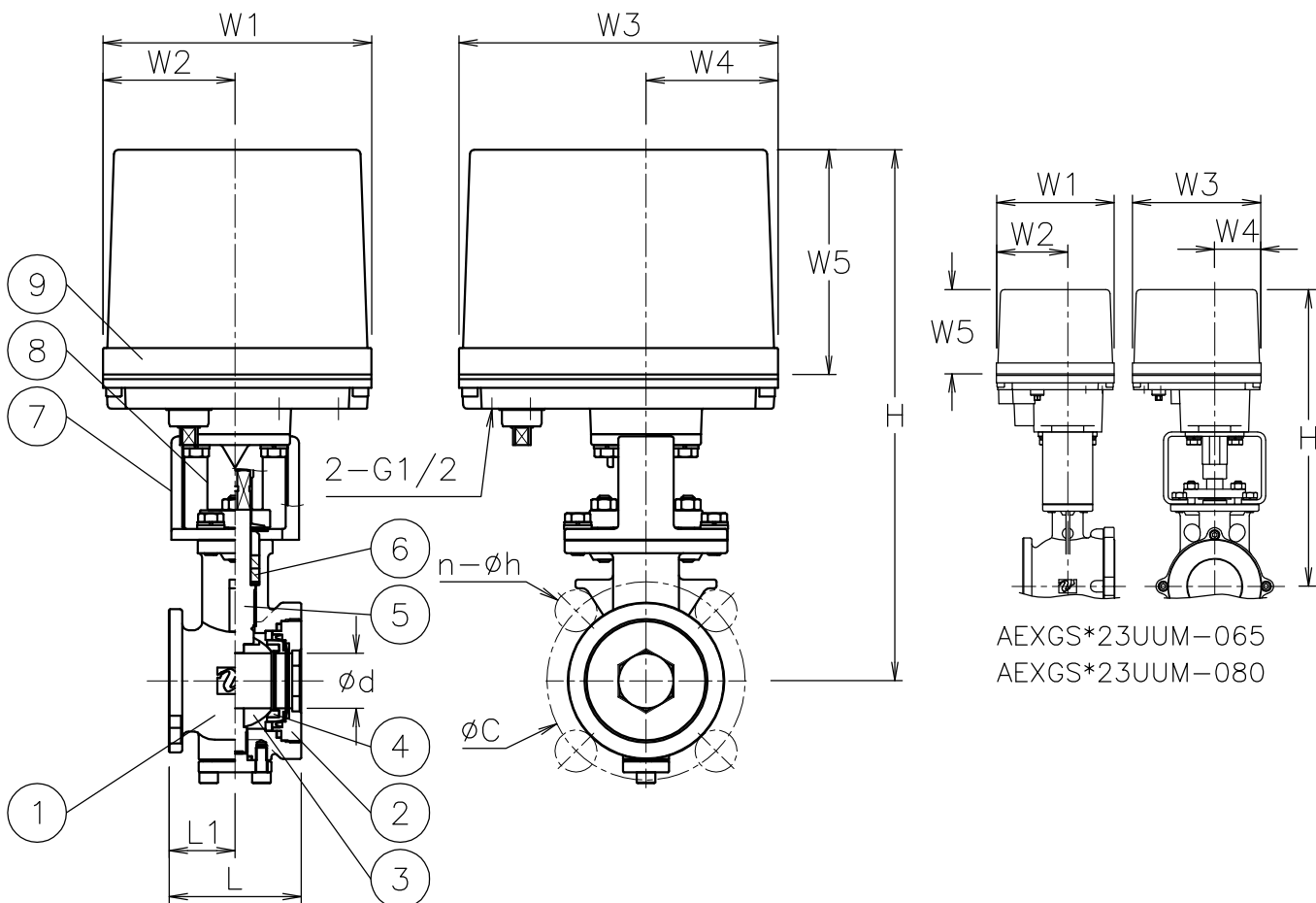

AEXGS*23UUM-065
AEXGS*23UUM-080

NOTE
付属品

- ・ケーブルコネクタ(ナイロン製), G1/2, 適合ケーブルφ6~12
- ・プラグ

9	電動操作機	アルミダ イラストケース	1	
8	コネクタ	SUS304/SCS13A	1	
7	ブラケット	SUS304/SCS13A	1	
6	パッキン	強化PTFE	2	
5	ステム	SUS316	1	
4	シート	SUS316	1	(ステライト盛)
3	ボール	SCS14A	1	HCr PLTD
2	キャップ	SCS14A	1	
1	本体	SCS14A	1	
No	DESCRIPTION	MATERIALS	REQ'D	REMARKS

			APPR'D	H. F	TITLE	J10K/20K ウエハー式 GS型コントロールバルブ			
			CHK'D	K. Y					
			DESIGN		MODEL	AEXGS**3UUM			
			DRAWN	S. O					
MARK	DATE	BY	DATE	'17-05-31	SCALE	NON	DWG No.	GS-*3UUM-EX13	
	REVISIONS								
	MV-2625								



NIPPON VALVE CONTROLS, INC.