

呼び径	d	L	D	J5K		J10K		H1	W1	W2	W3	W4	W5	H	質量 (kg)	Cv値	操作機型式	ランク
				C	n-h	C	n-h											
80 A	78	46	126	145	4-19	150	8-19	90	122	60	145	60	102	290	6.3	220	AE*-300	0
									122	60	145	60	102	306	6.3		AE*-600	2
100 A	98	52	146	165	8-19	175	8-19	107	122	60	145	60	102	336	7.8	410	AE*-600	0
125 A	126	56	180	200	8-19	210	8-23	129	122	60	145	60	102	359	9.9	800	AE*-600	0
									160	97	175	63	115	417	16		AE*-02K	2
150 A	150	56	211	230	8-19	240	8-23	147	160	97	175	63	115	442	19	1250	AE*-02K	0
200 A	196	60	257	280	8-23	290	12-23	189	160	97	175	63	115	472	25	2450	AE*-02K	0
250 A	246	68	322	345	12-23	355	12-25	222	195	75	220	75	130	567	41	4250	AE*-06K	0
300 A	295	78	367	390	12-23	400	16-25	260	195	75	220	75	130	607	51	6750	AE*-06K	0

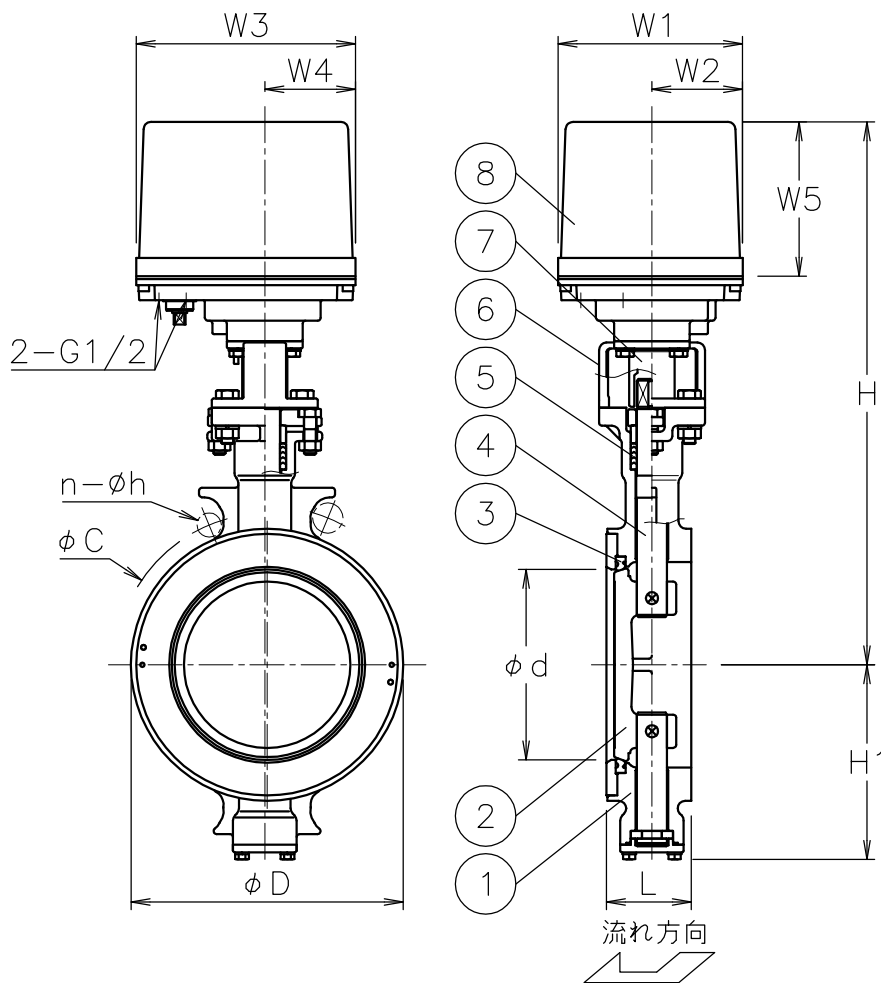

NOTE

付属品

- ・ケーブルコネクタ(ナイロン製), G 1/2, 適合ケーブル $\phi 6 \sim 12$
- ・プラグ

8	電動操作機	アルミダ イラストケース	1	
7	コネクタ	SUS304/SCS13A	1	
6	ブラケット	SCS13A	1	
5	パッキン	PTFE	1	
4	ステム	SUS304	1	
3	シート	F-PTFE	1	
2	弁体	SCS13A	1	
1	本体	SCS13A	1	
No	DESCRIPTION	MATERIALS	REQ' D	REMARKS

			APPR' D	H. F	TITLE	J5K/10Kウエハー式 DN型モータバタフライバルブ				
			CHK' D	K. Y						
			DESIGN		MODEL	AE1DN**1TTF AE2DN**1TTF				
			DRAWN	S. O						
MARK	DATE	BY	DATE	'17-12-08	SCALE	NON	DWG No.	DN-*1TTF-AE6		
REVISIONS			 NIPPON VALVE CONTROLS, INC.							
MV-2674										