

TA*BS901UUG-015
TA*BS901UUG-020

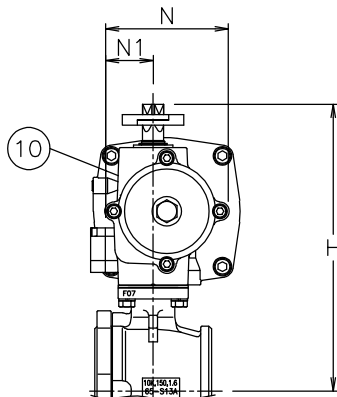

TA*BS9*1UUG-065
TA*BS9*1UUG-080

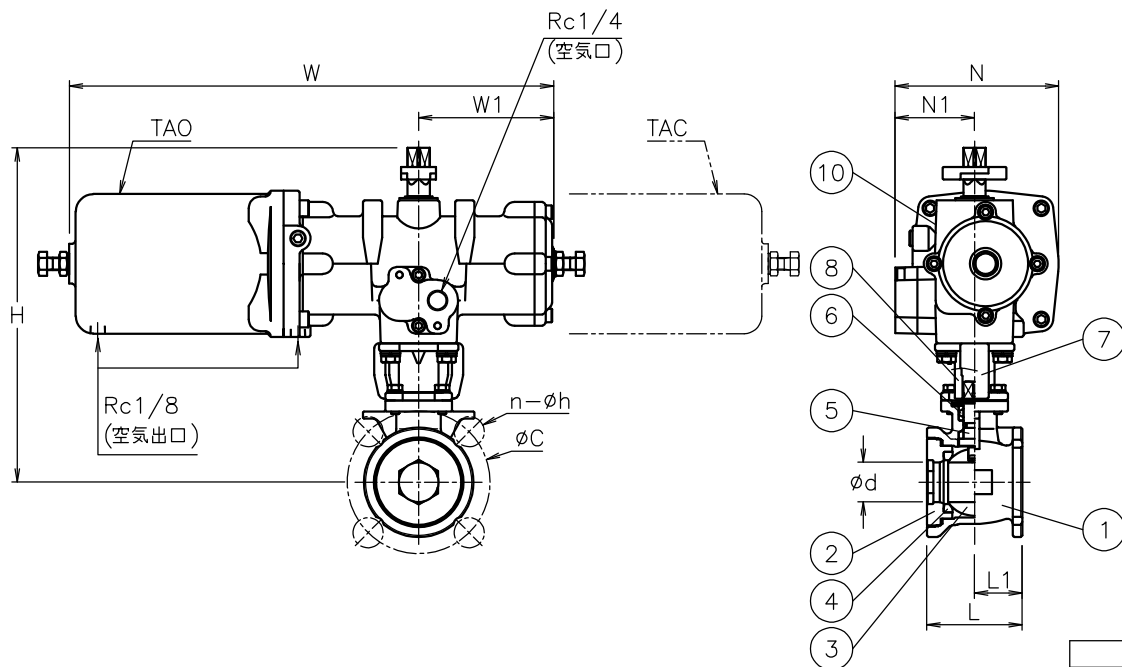

呼び径	d	L	L1	C	n-h	W	W1	N	N1	H	質量 (kg)	操作機型式		ランク
15 A	15	40	20	70	4-15	249	55	92	46	163	3.1	TAO-040	TAC-040	0
						305	85	103	50	201	3.8	TAO-050	TAC-050	2
20 A	20	50	25	75	4-15	249	55	92	46	166	3.3	TAO-040	TAC-040	0
						305	85	103	50	204	4	TAO-050	TAC-050	2
25 A	25	60	30	90	4-19	305	85	103	50	211	4.4	TAO-050	TAC-050	0
						367	102	119	52	226	6.4	TAO-063	TAC-063	2
32 A	32	70	35	100	4-19	305	85	103	50	217	4.9	TAO-050	TAC-050	0
						367	102	119	52	232	6.9	TAO-063	TAC-063	2
40 A	38	80	40	105	4-19	367	102	119	52	241	7.5	TAO-063	TAC-063	0
						435	120	142	59	282	12	TAO-080	TAC-080	2
50 A	50	95	47.5	120	4-19	367	102	119	52	250	8.8	TAO-063	TAC-063	0
						435	120	142	59	291	13	TAO-080	TAC-080	2
65 A	65	110	55	140	4-19	435	120	142	59	271	15	TAO-080	TAC-080	0
						530	147	174	71	302	23	TAO-100	TAC-100	2
80 A	74	125	62.5	150	8-19	435	120	142	59	278	17	TAO-080	TAC-080	0
						530	147	174	71	309	25	TAO-100	TAC-100	2

NOTE

- ① 標準操作圧力: 0.4~0.5MPa 最大0.7MPa
- ② 操作機動作

	空気導入	空気排出 (スプリング)
TAO	バルブ開	バルブ閉
TAC	バルブ閉	バルブ開

※ 図はTAO (逆作動) を表す

※ 標準仕様ではシステムの2次シールとしてFKMのOリングが付いています

10	エア作動操作機		1	TAO/C
9	延長ブラケット	BERIC	1	
8	コネクタ	SUS304/SCS13A	1	
7	ブラケット	SCS13A	1	
6	パッキン	強化PTFE	1set	
5	ステム	SUS316	1	
4	シート	強化PTFE	2	
3	ボール	SCS14A	1	
2	キャップ	SCS14A	1	
1	本体	SCS14A	1	
No.	DESCRIPTION	MATERIALS	REQ'D	REMARKS

			APPR'D	H. F	TITLE	J10Kウェハー形 (単作動形) BS型エア作動ボールバルブ					
			CHK'D	K. Y		MODEL	TAOBS9*1UUG TACBS9*1UUG				
			DESIGN				SCALE	NON	DWG No.	BS-9*1UUG-TD4	
MARK	DATE	BY	DATE	21-10-12							
REVISIONS											
MV-2936											