

HD*BF*11TTT-125

呼び径	d	L	L1	D	C	n-h	H	質量 (kg)	操作機型式			ランク
15 A	13	108	45	95	70	4-15	281	8.4	HD1-300	HD2-300	HD0-300	0
20 A	19	117	50	100	75	4-15	285	9	HD1-300	HD2-300	HD0-300	0
25 A	25	127	51	125	90	4-19	296	11	HD1-300	HD2-300	HD0-300	0
32 A	38	165	70.5	135	100	4-19	321	14	HD1-300	HD2-300	HD0-300	0
									HD1-700	HD2-700	HD0-700	2
40 A	38	165	70.5	140	105	4-19	321	14	HD1-300	HD2-300	HD0-300	0
									HD1-700	HD2-700	HD0-700	2
50 A	51	178	80.5	155	120	4-19	329	16	HD1-700	HD2-700	HD0-700	0
									HD1-700	HD2-700	HD0-700	0
65 A	64	190	87	175	140	4-19	368	22	HD1-700	HD2-700	HD0-700	0
									390	23	HD1-02K	HD2-02K
80 A	76	203	97	185	150	8-19	378	25	HD1-700	HD2-700	HD0-700	1
									400	26	HD1-02K	HD2-02K
100 A	102	229	116	210	175	8-19	436	37	HD1-02K	HD2-02K	HD0-02K	0
									468	63	HD1-02K	HD2-02K
125 A	127	356	148	250	210	8-23	473	68	HD1-06K	HD2-06K	HD0-06K	0
									493	88	HD1-06K	HD2-06K
200 A	203	457	207	330	290	12-23	546	115	HD1-06K	HD2-06K	HD0-06K	1

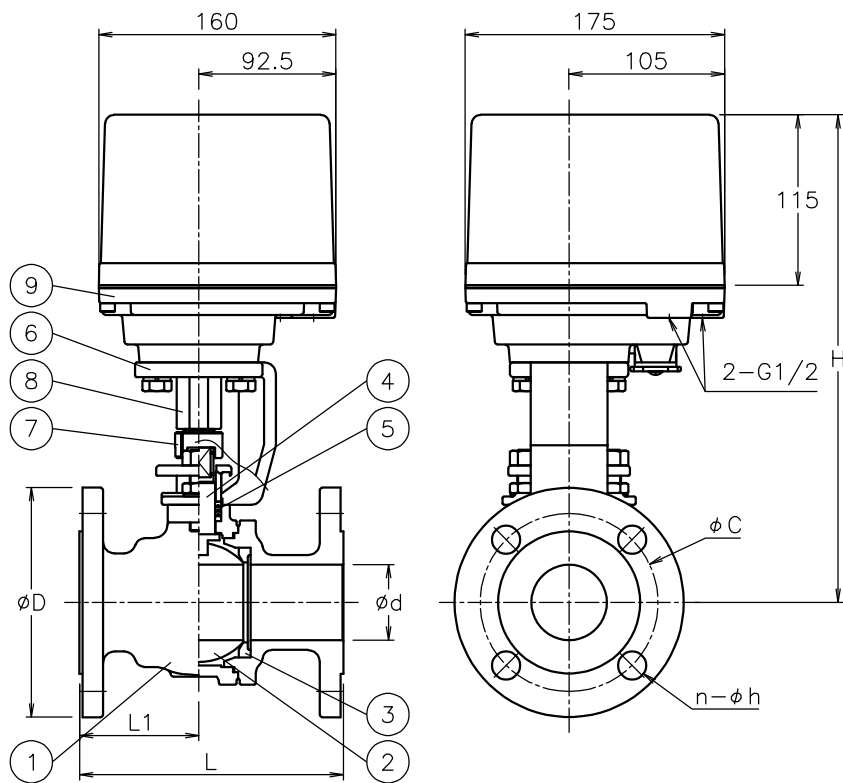

HD*BF*01TTT-125
HD*BF*01TTT-150
HD*BF*11TTT-200

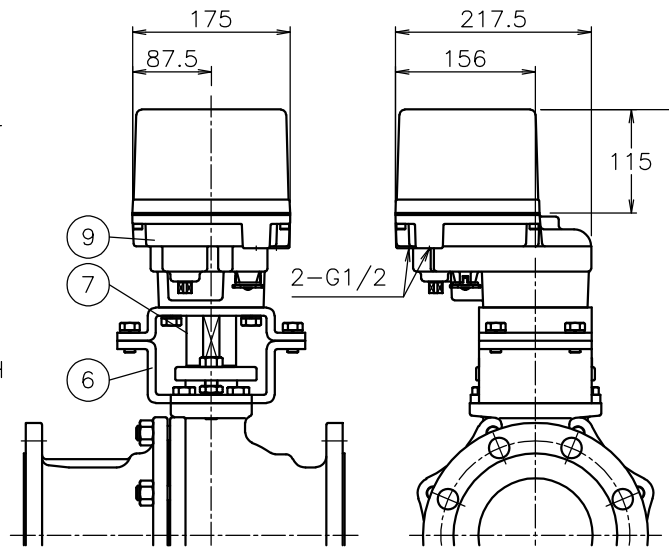

NOTE

付属品

- ・ケーブルグランド (ナイロン製), G1/2, 適合ケーブルφ6~12
- ・プラグ

No	DESCRIPTION	MATERIALS	REQ'D	REMARKS
9	電動操作機	アルミダイカストケース	1	
8	コネクタ	SCS13A	1	
7	コネクタ	SUSXM7/LAK52	1	125A (7mmφ) 150A
		SUS303/SUS304		065~100A 200A
		SCS13A		025~050A
		S45C		015, 020A 125A (7mmφ)
6	ブラケット	SS400	1	125~200A
		SCPH2		015~100A
5	パッキン	N-PTFE	1	
4	ステム	SUS304	1	
3	シート	N-PTFE	2	
2	ボール	SUS304/SCS13A	1	
1	本体	SCS13A	1	

MARK	DATE	BY	DATE	SCALE	NON	DWG No.	BF-*1TTT-HD12
			'23-11-16				
REVISIONS							
MV-3039							
APPR'D	K. Y			TITLE	J10Kフランジ形 BF型モータボールバルブ		
CHK'D	K. Y			MODEL	HD1BF**1TTT HD0BF0*1TTT		
DESIGN				SCALE	NON DWG No. BF-*1TTT-HD12		
DRAWN	P. O						



NIPPON VALVE CONTROLS, INC.